

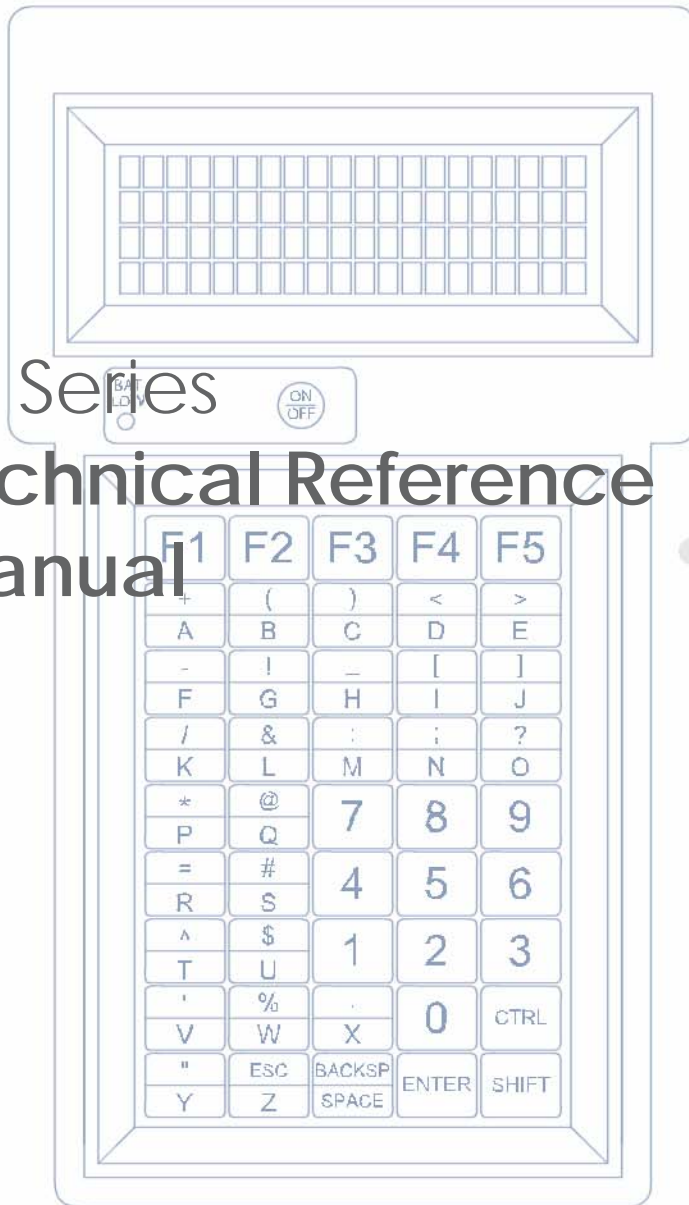

80 Series Technical Reference Manual



80 Series Technical Reference Manual

Document Number: MAN0330, Rev. C

Date of Last Revision: January 11, 2005

Copyright © 1998 – 2005, Two Technologies, Inc.

All rights reserved.

Printed in the United States of America

Copyrights and Trademarks

The 2T logo is a registered trademark and 80 Series is a trademark of Two Technologies, Inc.

Other products or company names mentioned herein may be the trademarks or registered trademarks of their respective companies.

Reproduction Rights

This manual contains proprietary information. Permission to reproduce or otherwise use portions of the material presented herein is explicitly given to Two Technologies OEMs incorporating the 80 Series into their products. Please note that this publication contains material that may not be appropriate for disclosure to some end users and that Two Technologies assumes no responsibility for technical support burdens incurred, or any other consequences of OEM documentation decisions.

Disclaimer

Two Technologies shall not be liable for technical or editorial errors or omissions contained herein; nor for incidental or consequential damages resulting from the furnishing, performance or use of this material.

Changes and Addendum

Information and specifications contained in this document are subject to change without prior notice and do not represent a commitment on the part of Two Technologies. However, Two Technologies may provide changed material as separate sheets included with this manual or separately in the form of a change package, as it deems necessary.

Contact Information

Two Technologies, Inc.
419 Sargon Way
Horsham, PA 19044
Phone: 215 441-5305
Fax: 215 441-0423
Web: www.2T.com

To contact Two Technologies by e-mail:

- Sales: sales@2t.com
- Customer Service: customersupport@2t.com
- Technical Support: techsupport@2t.com

Warranty Information

Seller warrants that the product specified in this agreement are free of defects in materials and workmanship, and shall conform to the latest specifications published prior to Buyer's acceptance of the agreement for a period of three years.

Product specifications as defined supersede previous specifications and are complete. Any parameter that is not specifically defined in the specifications is expressly excluded from the warranty. This warranty does not apply to any product which have been subject to misuse, accident, alteration, or if the unit has been serviced by anyone other than an authorized representative of Seller.

Seller's sole obligation to Buyer for products failing to meet specifications shall be, at Seller's discretion, to repair or replace the non-conforming device.

After receiving a Return Authorization (RA) number and a mailing address from Seller, a defective unit covered under this warranty may be returned freight prepaid. Any replacement or repaired product shall carry only the unexpired term of the warranty plus any the period required for repair.

If Buyer has been expressly designated as an Original Equipment Manufacturer (OEM) by Seller, the warranty period shall commence upon the earlier date of (i) delivery to Buyer's first customer, or (ii) 180 days from the original date of shipment by Seller. In the events that products for which: (a) Buyer has title and, (b) have never been used, and (c) have been in the Buyer's possession for more than 180 days and, (d) have an unaltered date code attached, may for an established fixed fee which will not exceed ten percent (10%) of the original purchase price, have the date code updated by the Seller and thereby reestablish those products with a new warranty.

THE FOREGOING WARRANTY AND REMEDIES ARE EXCLUSIVE AND ARE MADE EXPRESSLY IN LIEU OF ALL OTHER WARRANTIES EXPRESSED OR IMPLIED, EITHER IN FACT OR BY OPERATION OF LAW, STATUTORY OR OTHERWISE, INCLUDING WARRANTIES OR MERCHANTABILITY AND FITNESS FOR USE. TWO TECHNOLOGIES NEITHER ASSUMES NOR AUTHORIZES ANY OTHER PERSON TO ASSUME FOR IT ANY OTHER LIABILITY IN CONNECTION WITH THE SALE, INSTALLATION OR USE OF ITS PRODUCTS AND TWO TECHNOLOGIES MAKES NO WARRANTY WHATSOEVER FOR PRODUCTS NOT MANUFACTURED BY TWO TECHNOLOGIES.

TWO TECHNOLOGIES SHALL NOT BE LIABLE FOR DAMAGES DUE TO DELAYS IN DELIVERIES OR USE AND SHALL IN NO EVENT BE LIABLE FOR INCIDENTAL OR CONSEQUENTIAL DAMAGES OF ANY KIND, WHETHER ARISING FROM CONTRACT, TORT OR NEGLIGENCE, INCLUDING, BUT NOT LIMITED TO, LOSS OF PROFITS, LOSS OF GOODWILL, OVERHEAD OR OTHER LIKE DAMAGES.

To maintain your warranty and to avoid creating hazards, only qualified personnel should perform authorized modifications to Two Technologies' products. Two Technologies cannot assume responsibility for any condition affecting the proper operation of this equipment that may result from unauthorized modifications.

Product Returns

If, after inspection, you note any product damage or discrepancies, please contact us promptly within five days of receipt. If the exterior of the package shows obvious signs of damage, please contact your carrier directly.

All items returned to Two Technologies require a Return Material Authorization number (RMA). Please contact Two Technologies' Service department to request an RMA number.

Regulatory Notices

FCC Compliance

This equipment has been tested and found to comply with the limits for Class A digital device, pursuant to Part 15 of the FCC Rules. These limits are designed to provide reasonable protection against harmful interference when the equipment is operated in a commercial environment. This equipment generates, uses, and can radiate radio frequency energy and, if not installed in accordance with the instruction manual, may cause harmful interference to radio communications. Operation of this equipment in a residential area is likely to cause harmful interference, in which case the user will be required to correct the interference at his or her own expense.

Canadian Compliance

This digital apparatus does not exceed the Class A limits for radio noise emissions from digital apparatus set out in the Radio Interference Regulations of the Canadian Department of Communications

Le present appareil numerique n'emet pas de bruits radioelectrique depassant les limites applicables aux appareils numeriques de la class A prescrites dans le Reglement sur le brouillage radioelectrique edicte par le ministere des Communications du Canada.

Certifications

CENELEC



EMI Standards

- EN55022: 1998 (CISPR22, Class A) Information Technology

EMC Standards

- EN50082-1: 1997, General Immunity Part 1

Safety Standard

- EN60950: 2000 Safety of Information Technology Equipment

Warnings

Changes or modifications to this unit, which are not expressly approved by the party responsible for regulatory compliance, could void the user's authority to operate the equipment.

Electrostatic Discharge (ESD)



Electrostatic discharge (static electricity) can have unpredictable adverse effects on any electronic device. Although the design of the 80 Series incorporates extensive ESD-related precautions, ESD can still cause problems. It is good practice to discharge static by touching a grounded metal object before inserting cards or connecting devices.

Product Selection Guide

The 80 Series is a line of ASCII terminals for use with computers, properly equipped instruments and industrial machinery. Standard configuration includes a membrane keypad, twisted nematic liquid crystal display and modular interface connection, but other configurations are available. A suffix applied to the model number identifies the configuration as shown below:

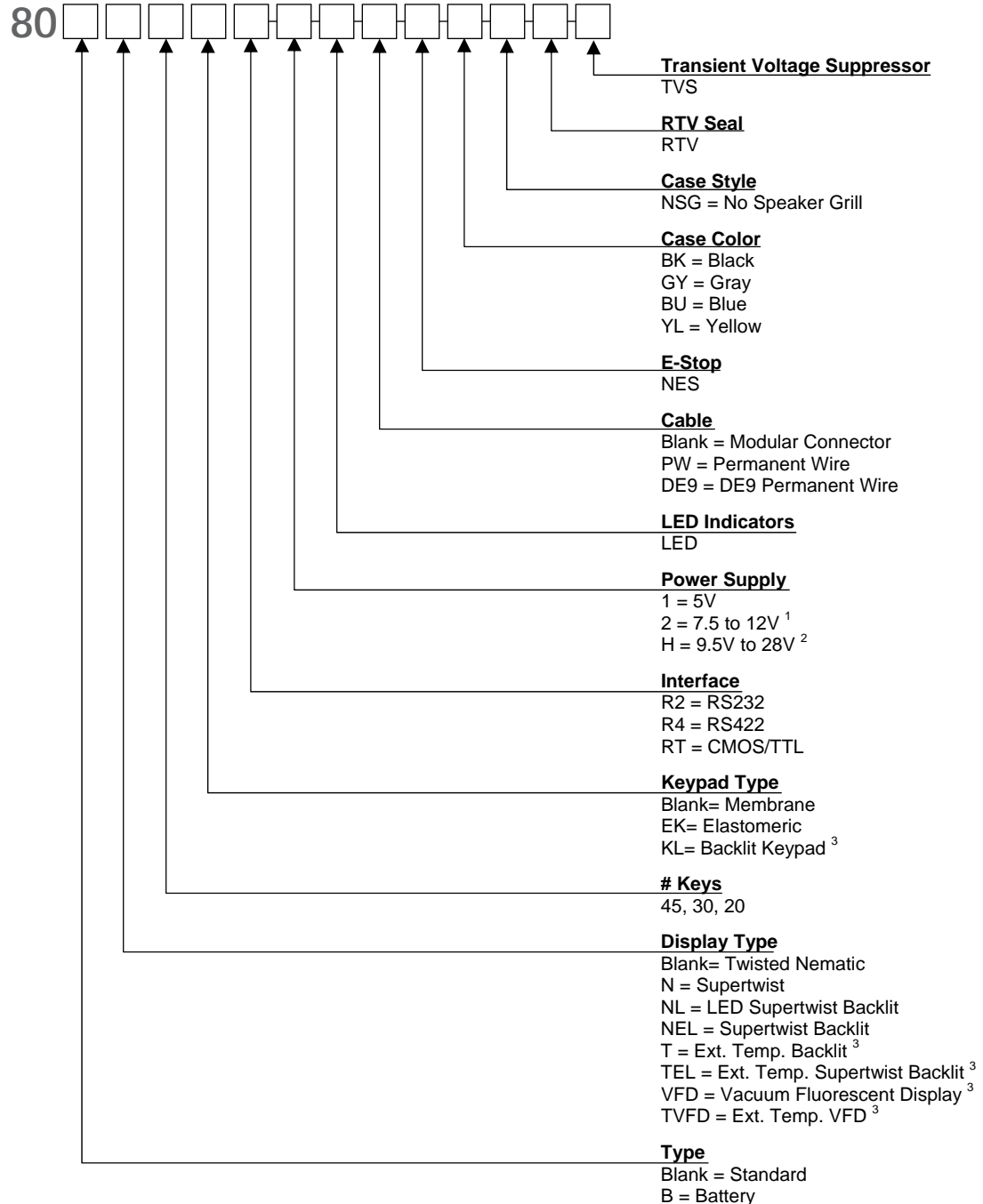

1. A linear regulator (7805A) with a minimum input of 7.5 V and a maximum voltage of 28.0 V that dissipates one watt of power thereby limiting maximum permissible input voltage according to current draw of terminal.
2. A switching type voltage regulator with a minimum input of 9.5 V and a maximum voltage of 28.0 V. Since input voltage is not dependent on the terminal's current draw, it is suitable for all options.
3. Not available on battery units

Power Requirements

Power Supply Options

Depending on the current draw requirements, the terminal may require the use of different power supplies. Use the configuration number listed below (see previous page) to determine the correct power supply:

- "-1" – requires connection to a 5-volt \pm 5% regulated power source.
- "-2" – requires connection to a power source between 7.5 and 12 VDC that can source adequate current. However, depending on a unit's total current draw, an input of up to 28 VDC may be applied. See chart on next page.
- "-H" – requires connection to a power source between 9.5 and 28 VDC that can source adequate current. However, input voltage is not dependent on a terminal's current draw and may be used with all terminal options.

Calculating Total Current Draw

The table below summarizes the current draw requirements for 80 Series terminals in various configurations (measured at its interface connector). Values listed are approximate due to variations in individual components – actual values may vary.

<i>Current Draw for Basic Configuration</i>		
<i>Configuration</i>	<i>Description</i>	<i>Draw</i>
80R2	Base Unit with RS-232	35 mA
80R4	Base Unit with RS-422	33 mA*
<i>Current Draw for Options</i>		
NL	LED Supertwist Backlit	Add 185 mA
NEL/TEL	Supertwist Backlit/Extended Temperature Backlit	Add 45 mA
VFD/TVFD	Vacuum Fluorescent Display/Extended Temperature VFD	Add 300 mA
KL	Backlit Keypad	Add 80 mA
LED	LEDS	4mA per LED
<i>Operational Current Requirements</i>		
	Handshake Low	Add 3 mA
	Handshake Floating (not connected)	Add 1 mA

*Worse case measurement, based on 4000 feet of cable, terminated with a 120-Ohm resistor.

To calculate the total current draw for your terminal configuration:

1. Read the model number on the back of your terminal.
2. Using the model number and the table above, add the current draw for each option to that of the base unit.

Example 1 – 80NEL45R2:

RS-232 Option	35 mA
Supertwist Backlit Display	45 mA
Calculated Total Current	80 mA

Example 2 – 80VFD45R2:

RS-232 Option	35 mA
Vacuum Fluorescent Display	300 mA
Calculated Total Current	335 mA

Determining the Maximum Input Voltage Allowed

The maximum input voltage allowed is based on a unit's current draw.

To determine the maximum input voltage allowed based on current:

1. Calculate the maximum current draw using the table on the previous page.
2. On the following chart, locate the Calculated Total Current on the **Calculated Operating Current** axis of the chart, and then move to the top of **Operating Voltage** range.
3. Look at the corresponding **Maximum Input Voltage Allowed** where the intersection occurs to find the maximum useable voltage for your terminal configuration.

Restricted Input Voltage vs. Current Draw

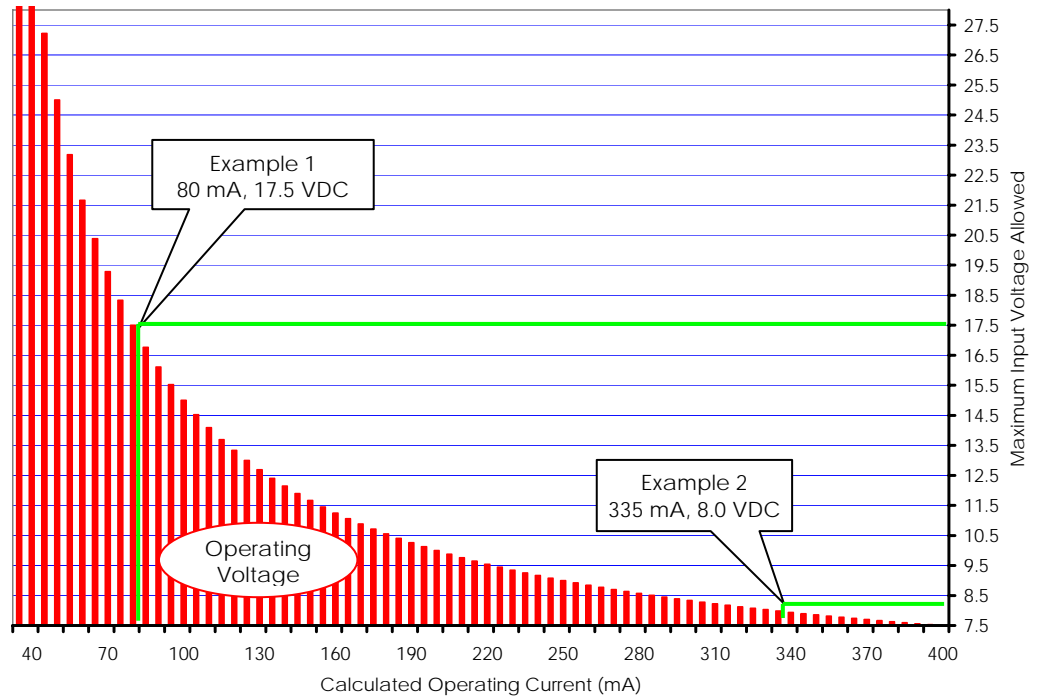

Using Example 1 and the chart above, the 80 mA drawn by the 80NEL45R2 intersects with 17.5 volts. If the maximum supply voltage to the terminal is greater than 17.5 VDC, it requires a -H power supply configuration.

Using Example 2 and the chart above, the 335 mA drawn by the 80VFD45R2 intersects with 8.0 volts. If the maximum supply voltage to the terminal is greater than 8.0 VDC, it requires a -H power supply configuration.

To clarify, if your system is supplying 12.0 VDC, the power is acceptable for the 80NEL45R2 (Example 1), but not for the 80VFD45R2 (Example 2). Applying 12.0 VDC to the 80VFD45R2 (Example 2) will **damage** it.

Contents

Chapter 1: Overview	1-1
About this Manual	1-1
Symbols and Conventions	1-1
About Two Technologies	1-1
About the 80 Series Terminal	1-2
80 Series Terminal Features	1-2
Chapter 2: Operation	2-1
Controls and Indicators	2-1
Cable and Power Connections	2-2
Internal Communication Devices	2-2
Signal and Pin Assignments	2-2
Connecting the Terminal	2-4
Power	2-4
Line-Powered Units	2-4
Battery-Powered Units	2-4
Keypad Operation	2-6
Display Operation	2-6
Cursor Position	2-6
Contrast Adjustment	2-7
E-Stop Operation	2-7
LED Indicators	2-7
Operating Modes	2-7
Host Control	2-8
Chapter 3: Manual Configuration	3-1
Introduction	3-1
Parameter Menu Settings	3-1
Baud Rate	3-1
Data Bits	3-1
Parity	3-1
Stop Bits	3-2
Display PE	3-2
Repeat	3-2
Key Click	3-2
KNP Function	3-3
Cursor	3-3
Cursor Blink	3-3
XON/XOFF	3-3
Handshake	3-3
Echo	3-3
Escape Mode	3-3
CR/LF Mode	3-4
Self-Test	3-4
Shift Lock	3-4
Scroll	3-4
Viewing Angle	3-4
Break Commands	3-5
Backlight	3-5
Parameter Menu Summary	3-5
Viewing Parameter Settings	3-6
Changing Parameter Settings	3-6
Loading Factory Default Settings	3-7
Restricting Access	3-7

Chapter 4: Function Key Programming	4-1
Introduction.....	4-1
Defining Function Keys	4-2
Extended Key Functionality	4-3
Break Commands	4-3
Output Control Commands.....	4-4
Pause Commands.....	4-4
Branching Commands	4-5
Handshake-Out Manipulation Commands	4-6
Extended Function Key Command Summary.....	4-7
Chapter 5: ANSI Mode Host Commands	5-1
Introduction.....	5-1
Cursor Commands	5-1
CR/LF Commands.....	5-2
Escape Mode Commands	5-2
Erasure Commands	5-3
Sound Commands	5-3
Display Attribute Commands.....	5-4
Key Attribute Commands.....	5-4
Self-Test & Return Commands	5-5
LED Control Commands	5-6
Parameter Modification Commands.....	5-7
Programming Key Commands	5-9
Custom Character Commands.....	5-10
Power Saver Commands.....	5-11
Advanced Control Mode	5-12
ACM Control Commands	5-13
Shift and Ctrl Key Control Commands	5-13
ANSI Mode Host Command Summary.....	5-16
Chapter 6: Private Host Commands	6-1
Introduction.....	6-1
Cursor Commands	6-1
Erasure Commands	6-3
Display Attribute Commands.....	6-3
Sound Commands	6-4
Escape Mode Commands	6-4
Key Attribute Commands.....	6-4
Return Commands.....	6-4
Private Mode Host Command Summary	6-5
Chapter 7: Control Codes	7-1
Chapter 8: Troubleshooting	8-1
Appendix A: Specifications	A-1
Appendix B: ASCII Character Set	B-1
Introduction.....	B-1
Appendix C: Font Tables	C-1
Standard Display Font Table.....	C-1
Latin1 Display Font Table.....	C-2
European Display Font Table.....	C-3
Appendix D: Keypad Hex Output Values	D-1
45-Key Keypad Hex Output	D-1
30-Key Keypad Hex Output	D-2
20-Key Keypad Hex Output	D-2
Index	I-1

List of Figures

Figure 2-1: 80 Series Controls and Indicators	2-1
Figure 2-2: Modular Interface Connector	2-2
Figure 2-3: DB-25 Interface Connector.....	2-2
Figure 2-4: 1210 Series Modular Cable	2-3
Figure 2-5: PCAT Modular Connector.....	2-3
Figure 2-6: Cable Connections	2-4
Figure 2-7: Changing Batteries	2-5
Figure 2-9: Standard Keypads	2-6
Figure 2-10: E-Stop Operation	2-7
Figure 2-11: E-Stop Switch Wiring	2-7
Figure 3-1: Parity Error Symbol.....	3-2
Figure 3-2: Handshake Symbol.....	3-3
Figure 3-3: Shift/Control Key Indicators	3-4
Figure 5-1: Ghost Key	5-12
Figure 5-2: Using ACM in a Robotic Environment	5-14
Figure 5-3: Using ACM in a Robotic Environment Flowchart	5-15
Figure A-1: 80 Series Terminal Case Dimensions	A-2

List of Tables

Table 2-1: 80 Series Controls and Indicators	2-1
Table 2-2: Interface Devices.....	2-2
Table 2-3: Modular Interface Connector Signal and Pin Assignments.....	2-2
Table 2-4: DB-25 Interface Connector Signal and Pin Assignments	2-3
Table 3-1: Communication Parameters Accessibility	3-2
Table 3-2: Parameter Menu Summary	3-5
Table 4-1: Function Key Hex Output Default Values	4-1
Table 4-2: Extended Function Key Command Summary.....	4-7
Table 5-1: Set Parameters Commands	5-8
Table 5-2: Programmable Characters.....	5-10
Table 5-3: ACM Mode- SHIFT and CTRL Key Results.....	5-13
Table 5-4: ANSI Mode Host Command Summary	5-16
Table 6-1: Private Mode Host Command Summary.....	6-5
Table 7-1: Control Codes	7-1
Table B-1: ASCII Character Set and Conversion Codes	B-1
Table C-1: Standard Display Font Table.....	C-1
Table C-2: Latin1 Display Font Table.....	C-2
Table C-3: European Display Font Table.....	C-3
Table D-1: 45-Key Keypad Hex Output Values.....	D-1
Table D-2: 30-Key Keypad Hex Output Values.....	D-2
Table D-3: 20-Key Keypad Hex Output Values.....	D-2



Chapter 1: Overview

About this Manual

Intended for developers familiar with operator interface applications, this manual describes the advanced features, operations and interface capabilities of Two Technologies' 80 Series terminals. It is not for use by end-users.

Unless otherwise stated, the operational characteristics described herein correspond to factory default configurations and settings as shipped from Two Technologies with a standard 45-key keypad (i.e., 8045).

Because 80 Series terminals are highly customizable products with several optional configurations and special keypad layouts, this manual only describes standard features and operation. For custom configurations and special options, consult the appropriate supplemental manual or addendum.

It is beyond the scope of this manual to provide operating system tutorials or information about commercial or customized 80 Series terminal application programs and connected equipment. This information should be available in the manuals that accompany those products.

Wherever used herein, the term "80 Series" applies to all models (except as noted).

NOTICE

The information contained in this manual applies only to 80 Series terminals manufactured after July 22, 2002 (Serial Number HH209081 and above).

Because newer models contain additional functions not found on previous models, use of these functions on older terminal may cause unexpected results.

Symbols and Conventions

Unless otherwise noted, this manual uses the following format conventions to distinguish elements of text:

- New terms used in this manual initially appear in *Italics*, for example: *host*.
- Names of keys as shown on a keypad appear in **bold type**, for example: **CTRL**.
- Names of parameter values appear in **uppercase letters**, for example: **ENABLED**.
- Esc represents the ASCII escape character in **Escape commands**, for example: **Esc [4n**.
- A lowercase "h" appearing after a number denotes a **hexadecimal value**, for example: **1Bh**.

About Two Technologies

Two Technologies has been producing rugged hand held and panel mount terminals and computers for over fifteen years. By implementing state of the art design and manufacturing techniques, we revolutionized hand held terminals and computers inside and out. Today, Two Technologies offers over a dozen cost-effective solutions serving virtually every market.

About the 80 Series Terminal

The 80 Series line of hand held terminals provide you with an industrial solution that offers flexible operation. The ANSI 3.64 (VT-100) compatibility makes it the perfect hand held solution for existing products. Nearly every aspect of operation—from the viewing angle (contrast control) to the function key definitions—are easily changeable utilizing simple menu selections or direct host control.

A rechargeable battery or the ability to use commercially available alkaline batteries for portable applications is one of many options available. A retractable hanger comes standard with the non-battery unit.

80 Series Terminal Features

Two Technologies offers 80 Series terminals with the following features. You can find additional information regarding specifications in [Appendix A](#).

Display

80 Series terminals come with a standard 80-character monochrome liquid crystal display that features the standard U. S. ASCII character set as dark characters on a light background. Cursor and view angle settings for the display can be menu or host-controlled.

Backlit, extended temperature and vacuum fluorescent displays, as well as optional character sets, such as Latin 1 or European are also available. 80 Series terminals also give you the ability to create custom characters not supported in the display's font table.

Keypad

Securely framed and clamped into place, the keypad surface provides excellent splash resistance and prevents curling or peeling of the keypad overlay. Keypad layouts include 45, 30, and 20 keys available with standard or custom graphics and 32 and 15 keys available with custom graphics. Keypads can be made from your choice of elastomeric or membrane material.

80 Series terminals can also have up to ten distinct function keys that you can define as characters or strings (maximum of 200 bytes overall) and save in non-volatile memory.

Switches and Indicators

Four host-controlled LED indicators are available as an option on 80 Series terminals.

Two Technologies offers 80 Series terminals with an option for Emergency Stop switch, which has a push-off, turn-reset motion. A fully depressed E-Stop opens all the circuits and can bring the machinery to a complete halt.

Interface Options

Interface options for 80 Series terminals include RS-232, RS-422 or CMOS/TTL protocols. Communication (up to 19,200 bps) with a host device is through a modular 6-pin connector.

Durability

Like all Two Technologies' products, an 80 Series terminal is remarkably rugged. The case consists of Cycloc ABS, one of the most durable, chemical-resistant materials available on the market today.



Chapter 2: Operation

Controls and Indicators

Figure 2-1 describes the possible components and indicators found on the front of an 80 Series terminal as shown in Table 2-1.

Figure 2-1: 80 Series Controls and Indicators

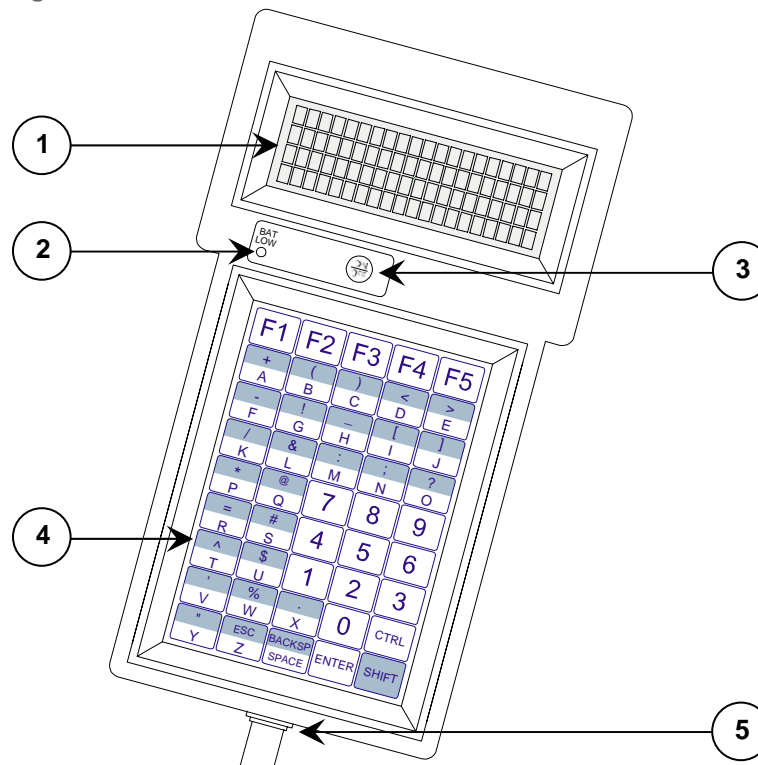

Optional E-Stop and LED indicators not shown

Table 2-1: 80 Series Controls and Indicators

<i>Item</i>	<i>Control/Feature</i>	<i>Description</i>
1	Display	4 Rows of 20 (5 x 7 pixel) characters
2	Low Battery Indicator	Battery-powered unit only
3	Power Switch	Battery-powered unit only
4	Keypad	45-key keypad (standard)
5	Modular Interface Connector	Supplies communication and power

Cable and Power Connections

Internal Communication Devices

The following table lists the internal interface devices used in the 80 Series terminal.

Table 2-2: Interface Devices

<i>Interface</i>	<i>Manufacturer</i>	<i>Device</i>
RS-232	Linear Technology	LT1281
RS-422	Linear Technology	LTC490

Signal and Pin Assignments

Modular Interface Connector

Figure 2-2 depicts the standard six-pin modular interface connector found on the 80 Series terminal. Table 2-3 describes its signal and pin assignments.

Warning: Use the six-pin modular receptacle for compatible serial devices only. Despite its physical similarity to modular telephone connectors, it is not compatible with telephone lines or signals. Connecting the terminal to a telephone line will damage it and void the warranty.

Figure 2-2: Modular Interface Connector

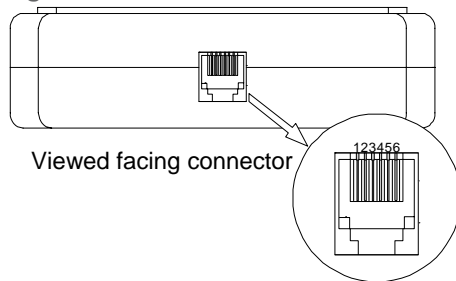

Table 2-3: Modular Interface Connector Signal and Pin Assignments

<i>Pin</i>	<i>RS-232/CMOS/TTL</i>	<i>RS-422</i>
1	+ Supply to terminal	+ Supply to terminal
2	Handshake-In to terminal	+ Data-In to terminal
3	Handshake-Out from terminal	+ Data-Out from terminal
4	Data-In to terminal	- Data-In to terminal
5	Data-Out from terminal	- Data-Out from terminal
6	Common	Common

Terminals with Optional E-Stops

80 Series terminals equipped with an optional E-Stop connect to host equipment via a non-detachable permanent wire cable that ends with a DB-25 male connector (Figure 2-3). Table 2-4 describes the signal and pin assignments for the DB-25 interface connector.

Figure 2-3: DB-25 Interface Connector

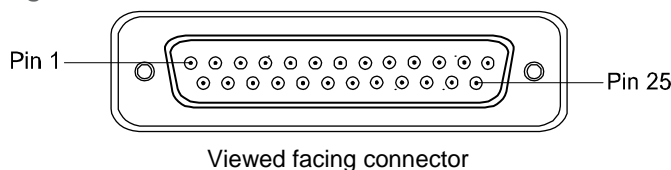

Table 2-4: DB-25 Interface Connector Signal and Pin Assignments

Pin	Color	Signal	Pin	Color	Signal
2	Yellow	Data-Out to terminal	13	Violet	E-Stop 1 (common)
3	Green	Data-In to terminal	14	Orange	E-Stop 1 (normally closed)
4	Red	Handshake-Out from terminal (RTS)	15	White	E-Stop 2 (common)
5	Black	Handshake-In to terminal (CTS)	16	Brown	E-Stop 2 (normally closed)
6	Red	Pin 20 (Jumpered)	20	Red	Pin 6 (Jumpered)
7	Blue	Common	25	Gray	+ Supply to terminal

Standard Accessory Cables

Standard modular cables (1210-7 and 1210-15) that mate with the terminal's modular interface connector and Two Technologies' PCAT wired adapter are available as optional accessories. These cables will reverse the signal output from the terminal (see illustration below). Non-reversing modular cables (1210-7-NR and 1210-15-NR) are also available.

Figure 2-4: 1210 Series Modular Cable

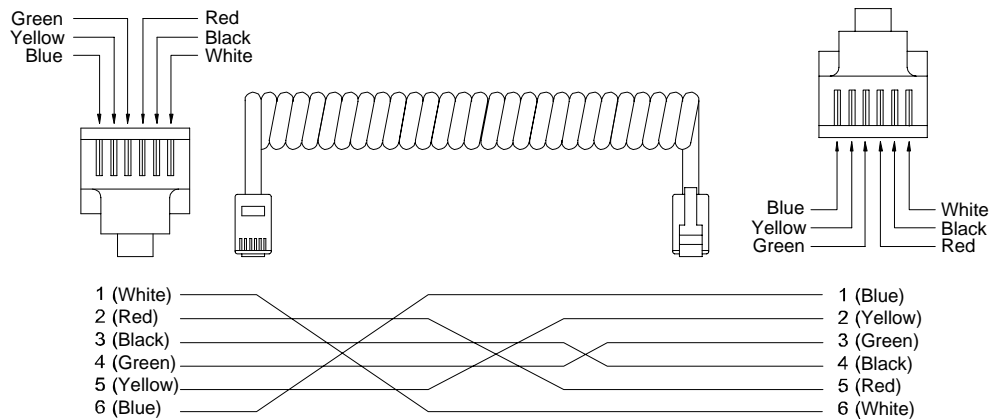

PCAT Wired Adapter

The PCAT modular connector enables connection to a host device as well as supplying a connection for a power supply.

Figure 2-5: PCAT Modular Connector

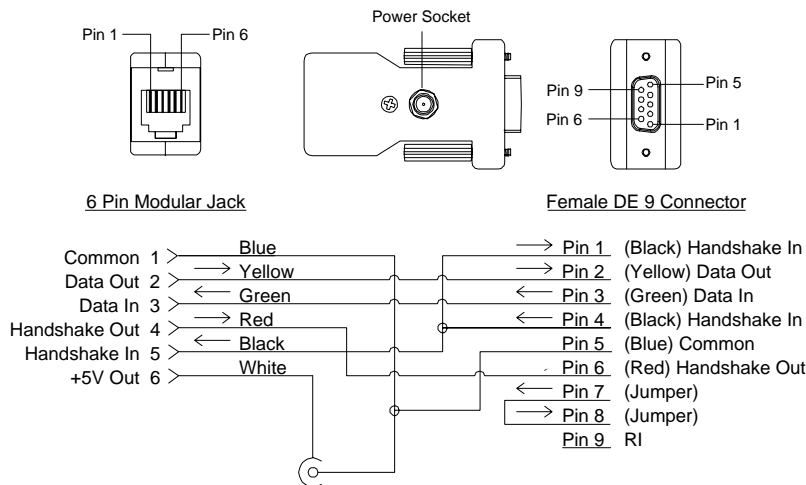

Note: Pin descriptions assume connection through a Two Technologies' 1210 series modular cable to the terminal's modular connector.

Connecting the Terminal

To connect the terminal to a host device using Two Technologies parts:

1. Plug one end of a [1210 modular cable](#) into the modular connector on the bottom of the terminal. Plug the other end into the [PCAT adaptor](#).
2. Plug the PCAT adapter into the host device.

Power

Line-Powered Units

To supply power to a line-powered 80 Series terminal:

1. Plug one end of a [1210 modular cable](#) into the modular connector on the bottom of the terminal. Plug the other end into the [PCAT adaptor](#).

Figure 2-6: Cable Connections

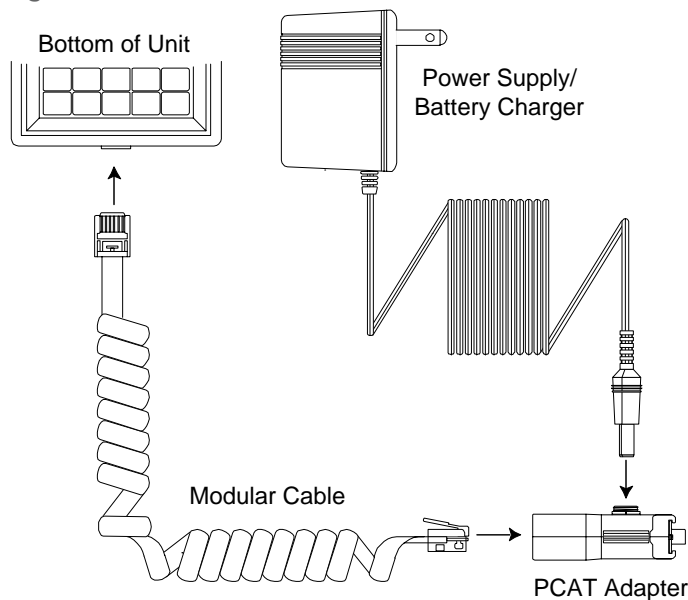

2. Using a Two Technologies' power supply (such as a Two Technologies 1226-1 linear power supply for units with a -2 power supply configuration), plug the power supply connector into the PCAT adapter and then plug the power supply into a 120 VAC 60 Hz power outlet.
3. The terminal should turn on and a blinking cursor should appear on the display. If the terminal does not turn on, refer to the [Troubleshooting](#) section of this manual for help.

Battery-Powered Units

Battery-powered 80 Series terminals come equipped with a rechargeable Nickel Metal Hydride (NiMH) battery that has exceptional charge life without the "charge memory" characteristic of conventional nickel cadmium batteries. Partially discharged batteries or extended periods with the charger left connected will not adversely affect battery life or performance.

Operating time on a full charge is up to 40 hours, depending on use. The time required for a full charge depends on the initial state of the battery. With the terminal off, this time should not exceed eight hours. Battery-powered 80 Series terminals can also operate on six AA alkaline batteries.

Battery-powered 80 Series terminals also have a low battery indicator, which indicates that there is approximately one hour of operating power remaining. A built-in power saver will turn off the terminal after ten minutes of inactivity. Any key press or character received by the terminal will reset the power-saver timer.

To turn on battery-powered units, press the On/Off switch. The terminal should turn on and a blinking cursor should appear on the display. If the terminal does not turn on, refer to the [Troubleshooting](#) section of this manual for help.

Charging the Unit

Because the internal battery charger senses several conditions, including temperature, you should charge the unit away from any known or potential heat sources. Units exposed to temperatures in excess of 90 degrees Fahrenheit during the charge cycle may experience incomplete charging and reduced operating time per charge.

To recharge the Nickel Metal Hydride (NiMH) battery pack, plug the Two Technologies' power supply/battery charger (Part # 13779) into the PCAT adapter and then plug the power supply/battery charger into a 120 VAC 60 Hz power outlet.

Changing Batteries

To change batteries:

1. With the unit face down, pull the battery cover retaining clip up from its recessed slot and turn the clip in a counter clockwise motion.
2. Lift the cover up and remove the batteries. If the unit contains a battery pack, use the tab on the battery pack to lift up and then out.
3. Insert the new batteries or battery pack into the unit using the orientation shown in the figure below.

Figure 2-7: Changing Batteries

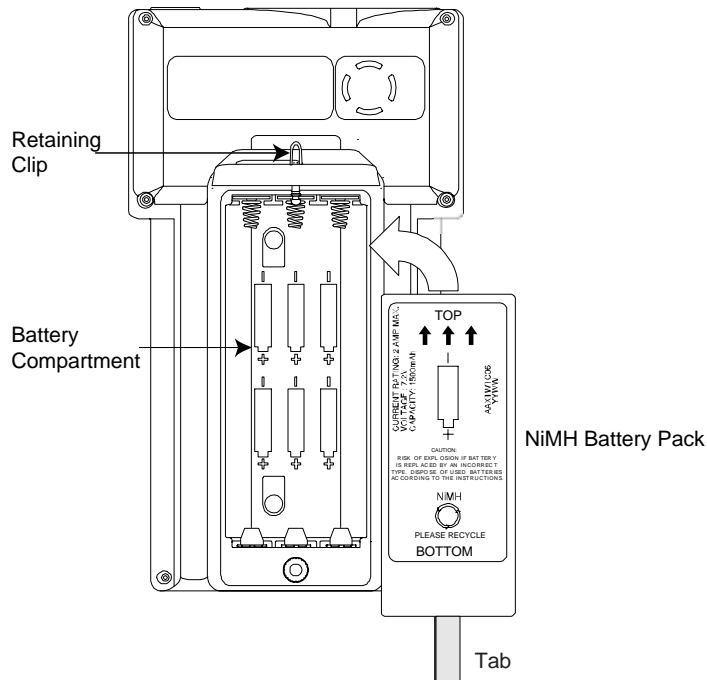

4. Close the battery cover and turn the battery cover retaining clip clockwise to lock the cover.

Keypad Operation

The standard 30 position and 45 position keypads consist of uppercase letters, digits 0 through 9, punctuation marks, symbols, function keys and keys for Escape (**ESC**), Space (**SPACE**), Backspace (**BACKSP/BKSP**), Control (**CTRL**), Shift (**SHIFT**) and Enter (**ENTER**). You can program the **SHIFT** key to operate in normal or locked mode. In the locked mode, pressing a modifier key will toggle its respective state.

Transmission of control characters will cancel the control state. If both the Shift and Control states are active, lowercase alphabetic characters will replace corresponding uppercase alphabetic characters. For information about control states, refer to the [Shift Lock](#) parameter setting.

On terminals with 30 and 45-key keypads, you can program up to ten function keys. On terminals with 20-key keypads, you can program up to four function keys. You can change these values and enter up to 20 characters per key (including non-printing characters) or enter special hex codes to control the transmission and display of characters between the host and terminal. For more information, see [Chapter 4: Function Key Programming](#).

The standard 20 position keypads consist of the digits 0 through 9, functions keys and keys for Yes (**YES**), No (**NO**), Backspace (**BKSP**), Space (**SPACE**) and Enter (**ENTER**).

Figure 2-8: Standard Keypads

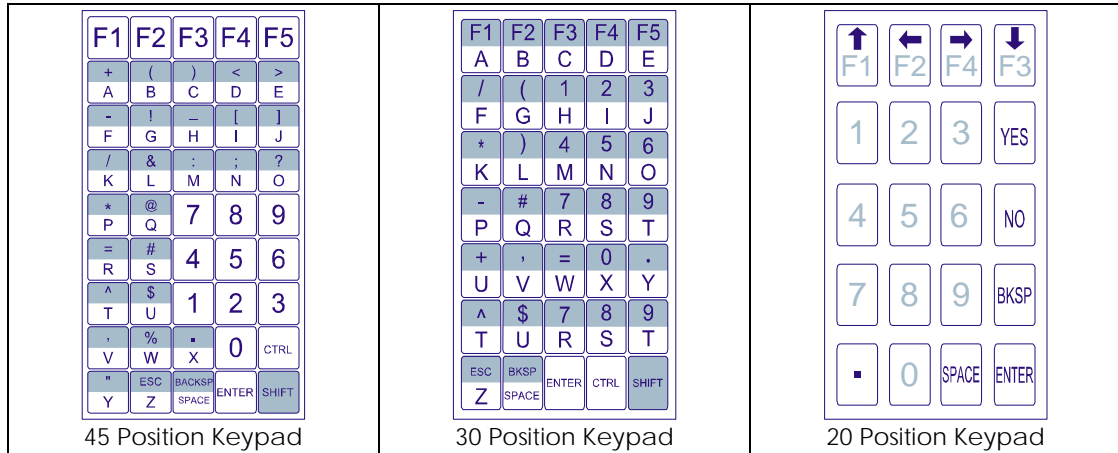

Display Operation

Standard 80 Series terminals display the U.S. ASCII 96 character set. However, other character sets, such as Latin 1 or European, are also available as an option. Characters appear on the display at the current cursor location.

Cursor Position

Typically, the cursor moves from left to right as the terminal displays characters (unless altered by Escape commands). The cursor is selectable as a block (enabled), hidden (disabled), blinking and non-blinking.

Whenever a character appears in the last position of the top three rows, the cursor will move to the leftmost position on the next row. By default, the terminal will hide the character in the last position on the bottom row (Position 80) with the cursor until it displays the next character. In which case, the screen will scroll up one row, the hidden character will appear in Position 80 and the cursor will appear in the rightmost position on a new bottom row. As an option, you can display a character in Position 80 and hide the cursor before the terminal display the next character.

For additional information about cursor and display options, see [Chapter 3: Manual Configuration](#), and [Chapter 5: ANSI Mode Host Commands](#).

Contrast Adjustment

On 80 Series terminals with standard 30 position and 45 position keypads, you can adjust the contrast by pressing **CTRL** and **F5**. There are eight adjustments levels. Each key press combination will make the display darker until it reaches the darkest maximum setting, in which case the next key press combination will result in the lightest maximum setting.

On 80 Series terminals with standard 20 position keypads as well as other keypad configurations, you can adjust the contrast by using ANSI Mode Escape commands, see [Chapter 5](#).

E-Stop Operation

The optional E-Stop switch consists of two normally closed switches. Pressing the switch opens both sets of contacts. Lamp connections are available only on optional illuminated switches.

Figure 2-9: E-Stop Operation

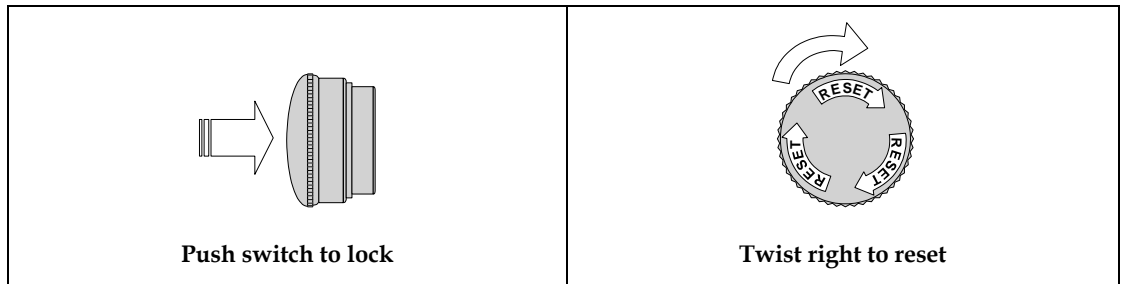
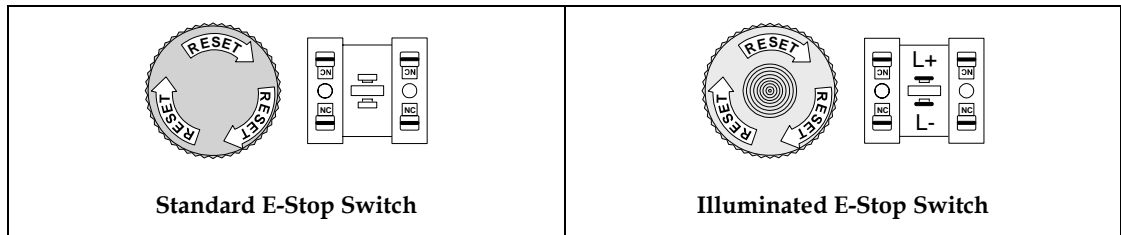

Figure 2-10: E-Stop Switch Wiring



LED Indicators

Four host-controlled LED indicators are available as an option on 80 Series terminals in red, amber or green. You can control the LEDs by using ANSI Escape commands. See [Chapter 5: ANSI Mode Host Commands](#) for more information.

Note: Battery-powered 80 Series terminals with LEDs, require that you use the rightmost LED as a low battery indicator.

Operating Modes

80 Series terminals have several operating modes. The default mode is Terminal mode. It allows the terminal to display characters, respond to commands sent by a connecting device, and send characters to the connecting device as keys are pressed. Other modes, described later in this manual, enable you to [set operating parameters](#) and [program function key definitions](#).

Host Control

The design of 80 Series terminals allows a connecting device (or “*host*”) to control its functions through the transmission of a string of special characters.

Referred to as “*Escape commands*” (because each character string begins with the ASCII escape character), these character strings enable the host to move the cursor to any position on the display, clear selected regions of the display, sound a beep, alert or key click, program the function keys and set any of the operating parameters.

80 Series terminals have two sets of built-in Escape command modes, ANSI and Private. The set in use is determined by the setting of the Escape Mode parameter.

When set to **ANSI mode**, the terminal recognizes a command set compatible with the American National Standards Institute Standard X3.64.

When set to **Private mode**, the terminal recognizes a smaller, non-standard set of commands.

The host can change the current Escape mode type at any time by issuing the corresponding Escape command.

Information about using [ANSI](#) and [Private Mode](#) Escape commands appears later in this manual.



Chapter 3: Manual Configuration

Introduction

A comprehensive set of user-settable operating parameters and programmable function keys makes the 80 Series terminal suitable for diverse applications. Each settable parameter and programmable function key has a default value. These values are stored in the terminal's permanent memory.

This chapter describes each operating parameter in detail, as well as how to set the parameters and load the default values. Chapter 4 covers programmable function keys.

Note: You can also program the terminal remotely using ANSI host commands. For more information, see [Chapter 5](#).

Parameter Menu Settings

The following section describes the parameters that you can program in an 80 Series terminal. A summary ([Table 3-2](#)) appears at the end of the section.

Baud Rate

This parameter sets the number of bits per second transmitted. The data rate can be set to: 300, 600, 1200, 2400, 4800, 9600 or 19200 baud. The default value is 9600.

Note: Baud rates above 9600 require handshaking.

Data Bits

This parameter sets the number of data bits transmitted per character, either seven (7) or eight (8). The default value is eight.

Note: Depending on the Data Bits and Parity settings, the Stop Bits and Display PE parameters may not be accessible. See [Table 3-1](#) for details.

Parity

This parameter enables/disables the host's ability to perform error checking on incoming characters and ensure accuracy. Allowable settings are NONE, IGNORE, EVEN, ODD, MARK and SPACE. The default value is NONE.

Selecting IGNORE will still add a parity bit to each character, but the value is indeterminate. Selecting NONE will prevent the sending of the parity bit. In either case, the host will not perform an error check on incoming characters.

Note: Depending on the Data Bits and Parity settings, the Stop Bits and Display PE parameters may not be accessible. See [Table 3-1](#) for details.

Stop Bits

This parameter sets the number of stop bits between each character transmission, either one (1) or two (2) with the following exceptions:

- A. When using 7-data bits and no parity, the terminal will automatically select 2-stop bits.
- B. When using 8-data bits and any parity the terminal will automatically select 1-stop bit.

In either case, the Stop Bits parameter will not be accessible. See [Table 3-1](#) for accessibility. The default value is one.

Display PE

When using parity checking, you can enable/disable this parameter to display a special character ([Figure 3-1](#)) when a parity error occurs. The default value is ENABLED. If the Parity parameter is set to IGNORE or NONE, the Display PE parameter will not be accessible. See [Table 3-1](#) for accessibility.

Figure 3-1: Parity Error Symbol



Table 3-1: Communication Parameters Accessibility

<i>Parameter Setting</i>		<i>Parameter Access</i>	
Data Bits	Parity	Stop Bits	Display PE
7	NONE	No	No
7	IGNORE	Yes	No
7	EVEN	Yes	Yes
7	ODD	Yes	Yes
7	MARK	Yes	Yes
7	SPACE	Yes	Yes
8	NONE	Yes	No
8	IGNORE	No	No
8	EVEN	No	Yes
8	ODD	No	Yes
8	MARK	No	Yes
8	SPACE	No	Yes

Repeat

This parameter determines the repeat keypad character rate while the key remains pressed. The allowable values are SLOW (6 characters per second), MEDIUM (10 characters per second), FAST (36 characters per second) and DISABLED. The default value is MEDIUM. In all cases, there is a short delay between the initial character and the start of the repeat.

Note: Should you enable the KNP function (disabled by default), the Repeat parameter will not be accessible.

Key Click

This parameter enables/disables the terminal's ability to emit an audible click each time a key is pressed, and for each repeated character. The default value is ENABLED.

KNP Function

The Key Not Press (KNP) parameter enables/disables the terminal's ability to detect the release of a key press. When set to ENABLED, the terminal will transmit the keypad character or function key data after a key press and a null (00h) character after a key release. The default value is DISABLED.

Note: Should you enable the KNP function (disabled by default), the Repeat parameter will not be accessible.

Cursor

This parameter enables/disables the terminal's ability to display a block cursor at the next character position. The default value is ENABLED.

Cursor Blink

This parameter enables/disables the cursor's ability to blink at a steady rate. The default value is ENABLED.

XON/XOFF

This parameter enables/disables the terminal's ability to control data flow with XON/XOFF protocol (i.e., When the receiving device is ready to receive data, it sends an XON signal to the sending device. When its buffer is full, the receiving device then sends an XOFF message to the sending device, which stops sending data). The default value is DISABLED.

Handshake

This parameter enables/disables use of handshake lines (DTR-DSR or RTS-CTS) for 80 Series terminals with an RS-232 interface. The default value is DISABLED.

When enabled, the terminal informs the host when it can and cannot accept data and vice versa. The Handshake-Out line is the signal to the host, and the Handshake-In line is the signal from the host.

If you enable both XON/XOFF and Handshake parameters, Handshaking has priority. For example, the terminal cannot send an XON/XOFF command to the host if the Handshake-In line is false (low).

Should you press a key on the terminal and the existing handshake condition prevents transmission to the host within approximately one second, the terminal will display a wait symbol (Figure 3-2).

Any subsequent key presses on the terminal will generate an audible tone. To cancel the waiting condition and send the waiting keystroke until the next keystroke, press **CTRL** and **F5** simultaneously.

Figure 3-2: Handshake Symbol



Echo

This parameter enables/disables the terminal's ability to display (echo) keypad entries on the screen. The default value is DISABLED.

Escape Mode

This parameter sets the Escape Command type used by the terminal to either ANSI or PRIVATE. The default mode is ANSI.

CR/LF Mode

This parameter determines which character is sent by the terminal to the host when the **ENTER** key is pressed, and how the terminal interprets a linefeed character sent by the host. Available options are **NORMAL** and **NEWLINE**. The default value is **NORMAL**.

In **NORMAL** mode, pressing **ENTER** on the terminal sends a carriage return to the host. A linefeed received by the terminal moves the cursor to the same column on the next line.

In **NEWLINE** mode, pressing **ENTER** on the terminal sends both a carriage return and a linefeed to the host. A linefeed received by the terminal moves the cursor to the first column on the next line.

Self-Test

This setting determines if the terminal will perform a confidence test at boot-up. The test initially displays the U.S. ASCII Character Set, performs a number of internal tests, and shows the model identifier string with checksum. The terminal will beep when the test is completed. If an error occurs, the terminal will display an error message. The default value is **DISABLED**.

Shift Lock

This parameter determines how the **SHIFT** and **CTRL** modifier keys are used. Typically, pressing the **SHIFT** key displays the symbols and characters that appear on the upper half of each key, while pressing the **SHIFT** key sends control characters to the host. Available options are **ENABLED**, **DISABLED** and **CANCEL**. The default value is **DISABLED**.

With Shift Lock enabled, pressing **SHIFT** will lock the keypad into Shift mode until you press **SHIFT** again.

With Shift Lock disabled, you must hold **SHIFT** and/or **CTRL** while pressing other keys.

With Shift Lock cancelled, pressing **SHIFT** and/or **CTRL** will modify only the next key press.

Figure 3-3: Shift/Control Key Indicators

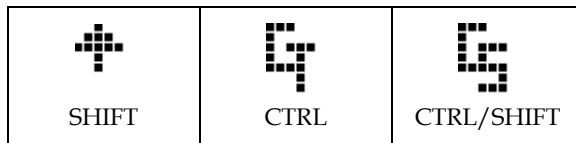

Scroll

This parameter determines how the scrolling function will work when the terminal displays a character in the last display position (lower right corner). Available options are 80 and 81.

When set to 80 (the default value), the screen will scroll up one line and position the cursor in the first column of the last line (lower left corner) after displaying a character in the last display position.

When set to 81, the screen will scroll up one line and position the cursor in the second column of the last line after displaying a character in the last display position and receiving the next displayable character from the host.

If the terminal receives a control code or an escape command that alters the cursor position, the cursor will remain at the last position and the pending scroll condition canceled.

Viewing Angle

This parameter adjusts the viewing angle for various environmental conditions based on contrast mid-point (which is set when you restore factory defaults). There are eight available settings: **MIN**, **MAX**, 7, 6, 5, 4, 3 and 2. The default value is **MID**.

Notes: You can also adjust the contrast by pressing CTRL and F5.

Break Commands

This parameter enables/disables the Break commands that define programmable keys. The default value is DISABLED.

Backlight

For units equipped with a backlight, this parameter turns the backlight on, completely off or off after 10 minutes of inactivity (in which case, any key press will reset the backlight timer and turn the backlight on). Allowable settings are ON, OFF or TIMED. The default value is ON.

Parameter Menu Summary

The following table lists the allowable settings and default values available through the Parameter menu. Default values appear in bold underlined text.

Table 3-2: Parameter Menu Summary

<i>Parameter</i>	<i>Options (Default In Bold)</i>
Baud	300, 600, 1200, 2400, 4800, <u>9600</u> , 19200
Data Bits	7, <u>8</u>
Parity	EVEN, ODD, MARK, SPACE, <u>NONE</u> , IGNORE
Stop Bits ¹	<u>1</u> , 2
Display PE ¹	<u>ENABLED</u> , DISABLED
Repeat ²	SLOW, <u>MEDIUM</u> , FAST, DISABLED
Key Click	<u>ENABLED</u> , DISABLED
KNP Function	ENABLED, <u>DISABLED</u>
Cursor	<u>ENABLED</u> , DISABLED
Cursor Blink	<u>ENABLED</u> , DISABLED
XON/XOFF	ENABLED, <u>DISABLED</u>
Handshake	ENABLED, <u>DISABLED</u>
Echo	ENABLED, <u>DISABLED</u>
Escape Mode	<u>ANSI</u> , PRIVATE
CR/LF Mode	<u>NORMAL</u> , NEWLINE
Test	ENABLED, <u>DISABLED</u>
Shift Lock	ENABLED, <u>DISABLED</u> , CANCEL
Scroll on Last Character	<u>80</u> , 81
Viewing Angle	MIN, <u>MAX</u> , 2, 3, 4, 5, 6, 7
Break Commands	ENABLED, <u>DISABLED</u>
Backlight ³	<u>ON</u> , TIMED, OFF

1. Access to parameter is dependent on Data Bits and Parity settings
2. Access to parameter is dependent on KNP Function setting
3. Only if the terminal has an optional backlit display

Viewing Parameter Settings

To scroll through the current parameter settings, simultaneously hold **CTRL** and **SHIFT**, and then press **F5** (**YES** on 20-key keypads). The terminal will display each setting for approximately one half second.

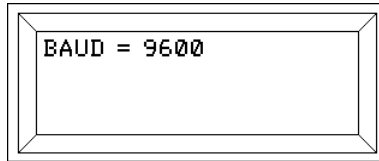

Changing Parameter Settings

To enter the Parameters menu and change settings:

1. For 45 or 30-key terminals, simultaneously hold **CTRL** and **SHIFT**, and press **F1**.
For 20-key terminals, simultaneously hold **BKSP** and **ENTER**, and press **F1**.

*Note: You can also access the Parameter menu, by removing power, simultaneously holding **CTRL**, **SHIFT** and **F3** (for 20-key terminals, use **BKSP**, **ENTER** and **F3**), and reapplying power.*

The Parameter menu appears with the first parameter on the top line.

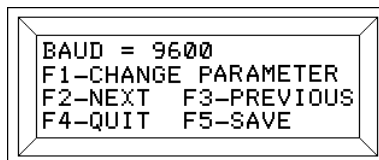

2. To change the value of the current parameter, press **F1**.
3. To view the next parameter, press **F2**.
4. To view the previous parameter, press **F3**.
5. To save any changes and exit the menu on 45 or 30-key terminals, press **F5**. To exit the menu without saving any changes, press **F4**.

To save any changes and exit the menu on 20-key terminals, press **F4**.

When saving changes, the terminal will sound an alert (three consecutive short beeps and prompt you to confirm your changes.

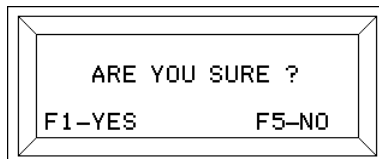

6. To confirm the changes, press **F1**.
To exit the menu without saving any changes on 45 or 30-key terminals, press **F5**.
To exit the menu without saving any changes on 20-key terminals, press **F4**.

Loading Factory Default Settings

To load the factory default settings:

1. Remove power from the terminal.
2. For 45 or 30-key terminals, simultaneously hold **CTRL**, **SHIFT** and **F1**, and reapply power.
For 20-key terminals, simultaneously hold **BKSP**, **ENTER** and **F1**, and reapply power.
3. After the terminal sounds an alert and displays the "LOAD DEFAULTS?" message, release the keys.

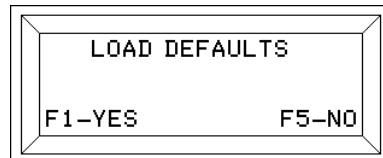

4. For 45 or 30-key terminals, press **F1** to reload the default values. Press **F5** to leave the parameters unchanged.
For 20-key terminals, press **F1** to reload the default values. Press **F4** to leave the parameters unchanged.

Restricting Access

If needed, you can prevent access to the Parameter menu and disable the following Escape commands: Set All Parameters (Esc [1z), Set and Save All Parameters (Esc [2z), Set All Defaults (Esc [3z) and Program Function Keys (Esc [5z).

To restrict access to the Parameter menu and disable related Escape commands:

1. Remove power from the terminal.
2. For 45 or 30-key terminals, simultaneously hold **CTRL**, **SHIFT** and **F3**, and reapply power.
For 20-key terminals, simultaneously hold **BKSP**, **ENTER** and **F3**, and reapply power.

In either case, the terminal will display the following message:

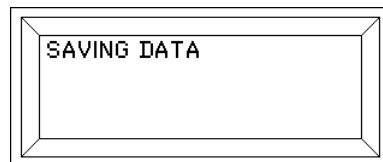

To re-enable access to the Parameter menu and related Escape commands, repeat the above procedure.



Chapter 4: Function Key Programming

Introduction

Function keys when pressed output the preset values as shown in [Table 4-1](#). You can change these values and enter up to 20 characters per key (including non-printing characters). These values are stored in the terminal's non-volatile memory. In addition to programming characters, you can enter special hex codes to control the transmission and display of characters between the host and terminal.

On terminals with 30 and 45-key keypads, you can program up to ten function keys. On terminals with 20-key keypads, you can program up to four function keys.

To access the first tier of function keys (F1-F5) on terminals with 45-key keypads, just press the function key. To access the second tier of function keys, press the **SHIFT** key and a function key.

To access the first tier of function keys (F1-F5) on terminals with 30-key keypads, press the **SHIFT** key and a function key. To use the second tier of function keys, you must first enable the SHIFT LOCK parameter. To access the second tier of function keys, press **SHIFT + CTRL + F1-F5**.

To display the results of key programming on your terminal, you should first enable ECHO.

When programming keys that use both the **CTRL** and **SHIFT** modifier keys, you should enable SHIFT LOCK to avoid conflicts with existing functions (e.g., pressing **CTRL**, **SHIFT** and **F1** accesses the Parameter menu) as well as prevent "Phantom Key" syndrome.

If your keypad has limited alphanumeric capability, you can program the function key using ANSI mode host commands. See [Programming Key Commands](#) for more information.

Table 4-1: Function Key Hex Output Default Values

Shaded areas represent modifier key combinations that are either unavailable in standard keypad configuration or not programmable.

<i>Keypad</i>	<i>Key</i>	<i>Normal</i>	<i>SHIFT</i>	<i>SHIFT + CTRL</i>	<i>CTRL (ANSI)</i>	<i>CTRL (Private)</i>
<i>45-Key</i>	F1	11h	06h	11h	1Bh 5Bh 41h	1Bh 41h
	F2	12h	07h	12h	1Bh 5Bh 42h	1Bh 42h
	F3	13h	08h	13h	1Bh 5Bh 43h	1Bh 43h
	F4	14h	09h	14h	1Bh 5Bh 44h	1Bh 44h
	F5	15h	0Ah	15h	1Bh 5Bh 45h	1Bh 45h
<i>30-Key</i>	F1	41h	11h	61h	01h	01h
	F2	42h	12h	62h	02h	02h
	F3	43h	13h	63h	03h	03h
	F4	44h	14h	64h	04h	04h
	F5	45h	15h	65h	05h 06h	05h 06h
<i>20-Key</i>	F1	41h	N/A	N/A	N/A	N/A
	F2	42h	N/A	N/A	N/A	N/A
	F3	43h	N/A	N/A	N/A	N/A
	F4	44h	N/A	N/A	N/A	N/A

Defining Function Keys

The following procedure describes how to define a function key using an 80 Series terminal:

1. On 30-key and 45-key terminals, simultaneously hold **CTRL**, **SHIFT** and **F2**. On 20-key terminals, simultaneously hold **BKSP**, **ENTER** and **F2**. The screen will display:

```
PRESS FUNCTION
KEY TO DEFINE?
```

2. Select a key to program, by pressing that key (for example, F1). The terminal will display the current value for that function key in the upper left corner.

Values preceded with "H" are in hexadecimal notation. Values enclosed in single quotes are in ASCII notation. For example, a 45-key terminal might display:

```
H11
F1=CHANGE f1 KEY
F3=NEXT      F5=EXIT
```

3. To change the current value, press **F1**.

To program another function key, press **F3**.

To exit, press **F5** (on 20-key terminals, press **F4**). When changing the current value, a 45-key terminal will display:

```
F1=QUIT F2=NEXT F3=←
F4=NUM  F5=SAVE
```

4. Using the keys on the keypad, type the characters you want to program into the key. For example:

```
'S' 'T' 'O' 'P'
F1=QUIT F2=NEXT F3=←
F4=NUM  F5=SAVE
```

5. You can also program the characters in hexadecimal or decimal notation, by pressing **F4**. In which case, the terminal will display:

```
H
ENTER 2 HEX DIGITS
F3=←      F4=DECIMAL
```

6. To program the characters in decimal notation, press **F4** again. The terminal will then display:

```
ENTER 3 DECIMAL NUMS
255 MAX. F3=← F4=HEX
```

7. Depending upon your numeric selection, type either two hexadecimal numbers or three decimal numbers for the first character.

8. For each subsequent character, press **F4** before entering the numbers.
You can find a list of available ASCII characters with Hex and Decimal equivalents in [Appendix B](#).
9. If you mistype a character or number, press **F3** to backspace.
10. To quit without saving, press **F1**.
11. To program another key, press **F2**.
12. To save the function key programming on 30-key and 45-key terminals, press **F5**. To save the function key programming on 20-key terminals, press **F4**.

When saving your changes, the terminal will display:

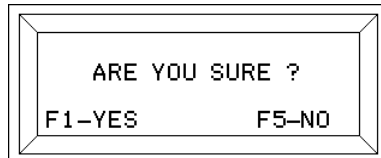

Warning! Do not remove power from the terminal while the above message appears on the screen or you will corrupt all stored data. Should you remove power during this time, you will have [load default values](#).

Notes: You can disable function key programming by simultaneously pressing **CTRL**, **SHIFT** and **F3** while applying power. Refer to the [Restricting Access](#) procedure for additional information.

To display the results of key programming on your terminal, you must enable ECHO. When programming a combination of keys that use both modifier keys (such as **CTRL** and **SHIFT**), you should enable the Shift Lock parameter to avoid conflicts with existing functions (such as **CTRL**, **SHIFT** and **F1** accesses the Parameter menu) as well as prevent Phantom Key syndrome.

Extended Key Functionality

Note: Before attempting to program keys with extended functionality, you must enable the Break Command parameter by using either the [Parameter Setup menu](#) or [ANSI Host Commands](#).

Extended Key commands are special hex codes that you use while defining key output to control the transmission and display of characters on both the terminal side and host side. For example, sending the string "START" to the host, while displaying "RUNNING" on the terminal. Extended Key commands fall into the following categories:

- Break Commands
- Output Control Commands
- Pause Commands
- Branching Commands
- Handshake-Out Line Manipulation Commands

Break Commands

When a communication line is idle, the normal state of the terminal, the line is *marking* or transmitting continuous series of ones. The marking signal is a voltage between -3 and -30 VDC. Break commands place the transmit line into a condition known as *spacing*, where the terminal is sending zeroes for a specified time (either 250 ms or 3.5 seconds). The spacing signal is a voltage between +3 and +30 VDC.

Short Break

When defining key output, enter BB as the two HEX digits to specify a break of 250 ms.

Long Break

When defining key output, enter BC as the two HEX digits to specify a break of 3.5 seconds

Output Control Commands

Normally, the terminal transmits data from a programmable key string serially. If you enable the Echo parameter, data also outputs to the display.

Toggle Display Echo

When defining key output, enter BE as the two HEX digits to allow any or all parts of a programmable key string to both transmit and display simultaneously. With terminal echo disabled, the terminal will transmit all characters after the Toggle Display Echo command to both the display and the serial port.

Escape commands echoed to the display that do not require serial output will process normally. Commands that require serial output are stored in the receiver buffer until the end of the current key string execution. Remember that this command is a toggle function and will operate according to the state of the terminal's Echo parameter setting.

Toggle Serial Output

When defining key output, enter BF as the two HEX digits to prevent the terminal from transmitting characters within a programmable key string.

When used in conjunction with the Toggle Echo command, you can control which parts of a programmable key strings display on the terminal parts of strings and which parts transmit to the host. For example, to send the string "START" to the host while displaying "RUNNING" on the terminal, your key output definition would look like:

```
'S' 'T' 'A' 'R' 'T' HBF HBE 'R' 'U' 'N' 'N' 'I' 'N' 'G'
```

Pause Commands

With the use of extended key functionality, you can program a key string to pause while either waiting to receive a specific character or a specific handshake line input.

Pause until Handshake Line Input is +V

When defining key output, enter B7 as the two HEX digits to suspend programmable key output until the terminal's handshake line (at the interface connector) is between +3 and +30 volts.

If the handshake line is already in the +V range, there should be no delays in output. Should the terminal wait for a response for more than 0.50 seconds, it will display the Wait character. To abort the pause, press **CTRL** and **F5** simultaneously.

Note: Use of this command requires that you disable the terminal's Handshake parameter.

Pause until Handshake Line Input is -V

When defining key output, enter B6 as the two HEX digits to suspend programmable key output until the terminal's handshake line (at the interface connector) is between -3 and -30 volts.

If the handshake line is already in the -V range, there should be no delays in output. Should the terminal wait for a response for more than 0.50 seconds, it will display the Wait character. To abort the pause, press **CTRL** and **F5** simultaneously.

Note: Use of this command requires that you disable the terminal's Handshake parameter.

Pause until n Character Received

When defining key output, enter BD as the two HEX digits to suspend communication until the terminal receives a specified character (n) from the host before continuing.

For example to have the terminal send the string "START," wait for a specific character (in this case, the letter "G" in the string "STARTING") and then respond to the host by sending the string "RUNNING" to the host, your key output definition would look like:

```
'S' 'T' 'A' 'R' 'T' HBF HBD 'G' HBF 'R' 'U' 'N' 'N' 'I' 'N' 'G'
```

Should the terminal wait for a response for more than 0.50 seconds, it will display the Wait character. To abort the pause, press **CTRL** and **F5** simultaneously.

Branching Commands

Branch commands enable you to access the contents of another function key.

Concatenate Function Key String

Use this command to append the contents of a specified function key to the end of the character string you are programming. As a result, you can display more than 20 characters with one key press.

When defining key output, enter the first nineteen characters as the first part of your character string, then enter either the hex value (F1 = F1, F2 = F2 ... F10 = FA) or the decimal value (F1 = 241, F2 = 242 ... F10 = 250) in the twentieth position for the function key containing the next part of character your string

For example to program the F1 key display the character string, "THIS STRING CONTAINS 34 CHARACTERS" using the contents of both F1 and F2 keys:

1. For F1, enter the first nineteen characters, then enter the numeric value (242) for F2:
THIS STRING CONTAIN 242
2. For F2, enter the remainder of the character string:
S 34 CHARACTERS
3. When you press F1, the terminal will now display:
THIS STRING CONTAINS 34 CHARACTERS
4. However, when you press F2, the terminal will also display:
S 34 CHARACTERS
5. To prevent the output of F2 you must use the Disable Function Key Output command (see next section)

Disable Function Key Output

When defining key output, you can enter BA as the two HEX digits to prevent the output of a character string programmed in a function key when that function key is pressed. For example to program the F1 key display the character string, "THIS STRING CONTAINS 34 CHARACTERS" using the contents of both F1 and F2 keys, but prevent the output of F2:

1. For F1, enter the first nineteen characters, then enter the numeric value (242) for F2:
THIS STRING CONTAIN 242
2. For F2, enter the hex value BA in the first position, then enter the remainder of the string:
BA S 34 CHARACTERS
3. When you press F1, the terminal will display:
THIS STRING CONTAINS 34 CHARACTERS
4. When you press F2, the terminal will not display any characters.

Branch to Function Key

When defining key output, enter BA as the two HEX digits to display the string programmed in *another* Function Key Number) and if needed, append the character string that follows. This functionality provides an alternative to disabling the output of a function key when appended to another function key.

For example to program the F1 and F2 keys to display same the character string, "THIS STRING CONTAINS 34 CHARACTERS" using the contents of both F1 and F2 keys:

1. For F1, enter the first nineteen characters, then enter the numeric value (242) for F2:
THIS STRING CONTAIN242
2. For F2, enter the decimal value for F1 (241) in the first position, then enter the remainder of the string:
241S 34 CHARACTERS
3. When you press either F1 or F2, the terminal will display:
THIS STRING CONTAINS 34 CHARACTERS

Conditional Branch

When defining key output, enter B5 as the two HEX digits to branch to the label value that follows when the Handshake-In line is between -3 and -30 volts.

If the Handshake-In line is between +3 and +30 volts, programmable key processing and output will continue normally with the character following the conditional branch's label value.

In the following example, the terminal acts as a remote monitoring device that checks the paper status and assumes the following:

1. The host will power up in a "STOPPED" state.
2. When the paper is low, the host asserts a -V on the line connected to the handshake input of the terminal.
3. When the unit begins to run, the host will transmit "R."
4. When the unit stops, the host will transmit "S."
5. Parameters settings for the terminal include DISABLE ECHO, ESCAPE MODE = PRIVATE and SCREEN SIZE = 24 x 8.

```
HBF HBE HB4 '1' H1B 'E' 'S' 'T' 'O' 'P' 'E' 'D' HB5 '2' H0D H0A 'P' 'A' 'P' 'E' 'R' ' ' 'L' 'O' 'W' '  
H4B '2' HBD 'R' H1B 'E' 'R' 'U' 'N' 'N' 'I' 'N' 'G' 'HB5 '3' H0D H0A P' 'A' 'P' 'E' 'R' ' ' 'L' 'O' 'W' '  
HB4 '3' HBD 'S' HBA '1'
```

Handshake-Out Manipulation Commands

Handshake-Out Manipulation commands are useful to signal an external device. The Handshake-Out line will maintain voltage levels between +3 and +15 volts or -3 and -15 volts. Effective line load resistance should always be greater than 3K ohms (RS-232 interface only).

Assert Handshake-Out Equals -V Command

When defining key output, enter B8 as the two HEX digits to assert the Handshake-Out line at the interface connector to between -3 and -15 volts (-V).

Note: Use of this command requires that you disable the terminal's Handshake parameter.

Assert Handshake-Out Equals +V Command

When defining key output, enter B9 as the two HEX digits to assert the Handshake-Out line at the interface connector to between -3 and -15 volts (+V).

Note: Use of this command requires that you disable the terminal's Handshake parameter.

Extended Function Key Command Summary

The following table is a summary of extended function key commands.

Table 4-2: Extended Function Key Command Summary

<i>Hex Code/Syntax</i>	<i>Command/Summary</i>
BC	Execute Long Break – specifies a break of 3.5 seconds
BB	Execute Short Break – specifies a break of 250 ms
BE	Toggle Display Echo – defaults to ECHO parameter setting
BF	Toggle Serial Output – defaults to serial output
BD <i>n</i>	Pause until <i>n</i> Character Received – wait to receive a specific character (<i>n</i>) from serial input
B7	Pause Until Handshake Line Input +V – suspend programmable key output until handshake line is between +3 and +30 volts
B6	Pause Until Handshake Line Input -V – suspend programmable key output until handshake line is between -3 and -30 volts
<i>String Fn</i>	Concatenate Function Key Output – append the character string preceding <i>Fn</i> (Function Key Number) to the function key designated in <i>Fn</i>
<i>Fn String</i>	Branch to Function Key – display the string programmed in <i>Fn</i> (Function Key Number) and if needed, append the character string that follows
B5 <i>Fn String</i>	Conditional Branch – if the Handshake-In line is -3 V to -30 V, display the output programmed in <i>Fn</i> (Function Key Number), else display the contents of <i>String</i>
BA	Disable Function Key Output – prevents the output of the character string that follows when the function key is pressed
B8	Assert Handshake-Out Equals -V Command – assert the Handshake-Out line, at the interface connector to between -3 and -15 volts
B9	Assert Handshake-Out Equals +V Command – assert the Handshake-Out line, at the interface connector to between +3 and +15 volts



Chapter 5: ANSI Mode Host Commands

Introduction

As discussed previously, the 80 Series terminal's design allows a host to control its functions by sending commands that begin with the Escape character. When set to ANSI mode, the terminal will recognize commands that are compatible with the American National Standards Institute X3.64 standard. For example, sending an Esc [H (1Bh 5Bh 48h) will move the cursor to the home position (upper right corner). A command summary appears at the end of this section.

Note: Do not use spaces between characters in Escape commands. Any spacing shown for Escape commands in this chapter is for clarity only unless otherwise noted.

Cursor Commands

Cursor Up

Syntax Esc [*Pn* A

Notes *Pn* indicates an optional repeat count. If the count is absent, the cursor will move one position. The cursor will not move beyond the start or end of a line, nor will it scroll the display.

Cursor Down

Syntax Esc [*Pn* B

Notes *Pn* indicates an optional repeat count. If the count is absent, the cursor will move one position. The cursor will not move beyond the start or end of a line, nor will it scroll the display.

Cursor Right

Syntax Esc [*Pn* C

Notes *Pn* indicates an optional repeat count. If the count is absent, the cursor will move one position. The cursor will not move beyond the start or end of a line, nor will it scroll the display.

Cursor Left

Syntax Esc [*Pn* D

Notes *Pn* indicates an optional repeat count. If the count is absent, the cursor will move one position. The cursor will not move beyond the start or end of a line, nor will it scroll the display.

Cursor Position

Syntax Esc [*Pr*; *Pc* f or Esc [*Pr*; *Pc* H

Notes *Pr* and *Pc* are the optional row and column numbers of the target cursor location, respectively. For example, Esc [4; 20 f will send the cursor to Row 4, Column 20.
If the row and column are absent, the command simply moves the cursor to the home position (i.e., Esc [H).

Cursor Home & Clear Display

Syntax Esc [1s

Save Cursor Position

Syntax Esc [s

Notes Temporarily stores the current cursor position in RAM memory and is lost when you remove power.

Restore Cursor Position

Syntax Esc [u

Notes Returns the cursor to the stored position.

Enable Cursor

Syntax Esc [4t

Disable Cursor

Syntax Esc [5t

Enable Blinking Cursor

Syntax Esc [6t

Enable Block Cursor

Syntax Esc [7t

CR/LF Commands

Normal Mode

Syntax Esc [20l

Notes This command changes the terminal's CR/LF mode parameter to NORMAL mode.

New Line Mode

Syntax Esc [20h

Notes This command changes the terminal's CR/LF mode parameter to NEWLINE mode.

Escape Mode Commands

Switch to Private Mode

Syntax Esc [?2l

Notes This command causes the terminal to switch from recognizing ANSI host commands to recognizing Private host commands.

Erasure Commands

Erase Cursor to End of Line

Syntax Esc [K

Notes Includes the character at the cursor location and does not alter the cursor position.

Erase Start of Line to Cursor

Syntax Esc [1K

Notes Includes the character at the cursor location and does not alter the cursor position.

Erase Entire Line

Syntax Esc [2K

Notes Includes the character at the cursor location and does not alter the cursor position.

Erase Cursor to End of Display

Syntax Esc [J

Notes Includes the character at the cursor location and does not alter the cursor position.

Erase Start of Display to Cursor

Syntax Esc [1J

Notes Includes the character at the cursor location and does not alter the cursor position.

Erase Entire Display

Syntax Esc [2J

Notes Includes the character at the cursor location and does not alter the cursor position.

Sound Commands

You cannot buffer sound commands. To produce properly spaced chain sounds, the host must delay a short time between issuing sound commands.

Short Bell

Syntax Esc [0q

Long Bell

Syntax Esc [1q

Alert

Syntax Esc [2q

Key Click

Syntax Esc [3q

Display Attribute Commands

Set Blink Attribute

Syntax Esc [2s

Notes Enables characters on the display to blink. Characters written subsequent to the setting or clearing of attributes will assume the new attribute characteristics.

Clear Blink Attribute

Syntax Esc [3s

Notes Stop characters on the display from blinking. Characters written subsequent to the setting or clearing of attributes will assume the new attribute characteristics.

Adjust LCD Contrast

Syntax Esc [v

Notes This command increases the contrast one level

Enable Backlight

Syntax Esc [8t

Notes Applies only to terminals with optional backlit displays

Disable Backlight

Syntax Esc [9t

Notes Applies only to terminals with optional backlit displays

Key Attribute Commands

Enable Key Repeat

Syntax Esc [?8h

Notes This command enables key repeat, using the most recent rate setting.

Disable Key Repeat

Syntax Esc [?8l

Enable Key Click

Syntax Esc [0t

Disable Key Click

Syntax Esc [1t

Enable KNP Function

Syntax Esc [2t

Disable KNP Function

Syntax Esc [3t

Self-Test & Return Commands

Perform Self-Test & Return Results

Syntax Esc [4n

Notes This command performs the built-in confidence test and reports the result.
A response of Esc [0n indicates that the terminal passed the confidence test; a response of Esc [3n indicates that the confidence test has not run or that a malfunction occurred.

Return Last Self-Test Results

Syntax Esc [5n

Notes This command reports the result of the last confidence test run since the terminal power up.
A response of Esc [0n indicates that the terminal passed the confidence test; a response of Esc [3n indicates that the confidence test has not run or that a malfunction occur.

Return Device Attributes

Syntax Esc [c

Notes This command sends the following string to the host indicating that the terminal is ANSI 3.64/VT100 compatible: Esc [?8; 4c.

Return Terminal Identifier String

Syntax Esc [p

Notes This commands sends the following identifier string to the host:
Esc [0x 80*NN* *CCCC* Esc [1x
Where *NN* is the keypad type (20, 30 or 45) and *CCCC* is the four-byte hexadecimal checksum of the terminal's program memory.
When using this command to identify the terminal type, do not include the checksum as it may change.

Return Cursor Position

Syntax Esc [6n

Notes This command sends the cursor's current location to the host in the form:
Esc [*Rn*; *Cn* R
Where *Rn* is the row number and *Cn* is the column number. For example, a return of Esc [4; 21R indicates a cursor position of Row 4, Column 21.
When the Scroll parameter is set to LAST CHR+1, a return of Esc [8; 25R or Esc [16; 33R (depending on the screen size) represents the cursor position after a character is written to Row 8, Column 24 or Row 16, Column 32.

LED Control Commands

On models equipped with optional LED indicators, the following commands control LEDs usage:

Disable LED 1

Syntax Esc [6q

Enable LED 1

Syntax Esc [7q

Disable LED 2

Syntax Esc [8q

Enable LED 2

Syntax Esc [9q

Disable LED 3

Syntax Esc [10q

Enable LED 3

Syntax Esc [11q

Disable LED 4

Syntax Esc [12q

Enable LED 4

Syntax Esc [13q

Disable All LEDs

Syntax Esc [16q

Parameter Modification Commands

You can change the terminal's parameter settings from the host using Escape commands. You can issue commands for individual settings, all settings or simply report the current settings.

The Set Defaults command resets all parameters and keys to their default settings. The Set Parameters command enables you to change but not save parameters to memory. The Set and Save Parameters command enables you to change and save parameters to memory.

Note: If you have [restricted access](#) to the Parameter menu, you cannot use these commands.

Set Defaults

Syntax Esc [3z Esc [0z

Set Parameters

Syntax Esc [1z P1; P2; P3; P3A; . . . P20 Esc [0z

Set and Save Parameters

Syntax Esc [2z P1; P2; P3; P3A; . . . P20 Esc [0z

Set Parameters & Set and Save Parameters Command Notes

Both commands can specify up to 21 single character parameters from a fixed list (see [Table 5-1](#)).

You can omit any or all of the parameters by using the semicolon as a placeholder, except in the case of P3A (STOP BITS). P3A is only significant if specified.

P3A has the following characteristics:

1. You cannot substitute P3A with a placeholder. The terminal will interpret a placeholder in the P3A position as a placeholder for P4.
2. You can specify P3A even if P3 has a placeholder.
3. In certain situations, the terminal will automatically set the number of stop-bits to either one (when you select eight data-bits and any parity) or two (when you select seven data-bits and no parity). In either case, the setting of P3A will have no effect.

Parameter values not specified in the Set All Parameters and Set and Save All Parameters commands will remain unchanged.

After the terminal has processed a Set All Parameters or Set and Save All Parameters command, it will send the new parameters setting the host as ASCII text, with each parameter followed by a carriage return and line feed.

To send the current parameter values to the host without changing any values, simply send: Esc [1z Esc [0z.

Table 5-1: Set Parameters Commands

<i>Parameter</i>	<i>Name</i>	<i>Options</i>
P1	Baud	<u>3</u> 00, <u>6</u> 00, <u>1</u> 200, <u>2</u> 400, <u>4</u> 800, <u>9</u> 600, 19200
P2	Data Bits	<u>7</u> or <u>8</u>
P3	Parity	<u>E</u> VEN, <u>O</u> DD, <u>M</u> ARK, <u>S</u> PACE, <u>N</u> ONE, <u>I</u> GNORE
P3A	Stop Bits	<u>1</u> or <u>2</u>
P4	Display PE	<u>E</u> NABLED, <u>D</u> ISABLED
P5	Repeat	<u>S</u> LOW, <u>M</u> EDIUM, <u>F</u> AST, <u>D</u> ISABLED
P6	Key Click	<u>E</u> NABLED, <u>D</u> ISABLED
P7	KNP Function	<u>E</u> NABLED, <u>D</u> ISABLED
P8	Cursor	<u>E</u> NABLED, <u>D</u> ISABLED
P9	Cursor Blink	<u>E</u> NABLED, <u>D</u> ISABLED
P10	XON/XOFF	<u>E</u> NABLED, <u>D</u> ISABLED
P11	Handshake	<u>E</u> NABLED, <u>D</u> ISABLED
P12	Echo	<u>E</u> NABLED, <u>D</u> ISABLED
P13	Escape Mode	<u>A</u> NSI, <u>P</u> RIVATE
P14	CR/LF Mode	<u>N</u> ORMAL, <u>N</u> EW <u>L</u> INE
P15	Test	<u>E</u> NABLED, <u>D</u> ISABLED
P16	Shift Lock	<u>E</u> NABLED, <u>D</u> ISABLED
P17	Scroll On	<u>0</u> (LAST CHR) or <u>1</u> (LAST CHR +1)
P18	Viewing Angle	<u>1</u> (Min) , <u>2</u> , <u>3</u> , <u>4</u> , <u>5</u> , <u>6</u> , <u>7</u> , <u>8</u> (Max)
P19	Break Command	<u>E</u> NABLED, <u>D</u> ISABLED
P20	Backlight ¹	<u>O</u> N, <u>T</u> IMED, <u>O</u> FF

Example

The following command will enable communications at 9600 baud, 8 data bits, even parity and 1 stop bit. In addition, it will disable the parity error symbol, use fast repeat, enable the key click, disable the KNP function, enable the cursor, disable cursor blink, enable XON/XOFF protocol, and enable handshaking. It will also disable echo, use ANSI escape mode commands, set CR/LF Mode to normal, enable self-test, disable the shift lock, set the scroll on to the last character, set the viewing angle to 4, disable the break command and turn on the backlight.

```
Esc [1z 9; 8; E; 1; D; F; E; D; E; E; D; A; N; E; D; 0; 4; D; O; Esc [0z
```

Programming Key Commands

You can issue ANSI host commands to reprogram the terminal's function keys to transmit a single character or a string of characters. However, if you have [restricted access](#) to the Parameter menu, you cannot use these commands.

Program Key

Syntax Esc [5z *fn*|*Fn*; C1; C2; . . . C20 Esc [0z

Notes This command reprograms a function key , where *fn* represents a non-shifted function key number, *Fn* represents a shifted function key number (applies to 30-key and 45-key keypads) and C1, C2 . . . C20 are the character values in ASCII Hex notation ("A" = 41, "B" = 42, etc.).

For example, to program F1 to display the string "STOP" when pressed, issue the following command:

```
Esc [5z f1; 53; 54; 4F; 50 Esc [0z
```

To program F1 to display the string "RESTART," when pressed in conjunction with the SHIFT key, issue the following command:

```
Esc [5z F2; 45; 53; 54; 41; 52; 54 Esc [0z
```

Should the terminal encounter an error during key programming, it will terminate the programming operation without allocating memory and return the following error string:

```
Esc [0x ERROR CODE= X PARAMETERS UNCHANGED Esc [1x
```

Where X is one the following ACSII Hex error codes:

- A = Invalid value or format specified in *fn*|*Fn*
- B = Invalid format specified in C1; C2; . . . C20
- C = Invalid value specified in C1; C2; . . . C20

After the terminal successfully receives the Esc [0z termination command, it inserts the programming information into memory. Should you remove power within 0.75 seconds of this time, all programmed key data may become corrupt and subsequently require you to load the default parameters.

Report Key Settings

Syntax Esc [4z

Notes This command sends a list of keys programmed with values other than the default values to the host using the format:

```
Esc [0xffn; C1; C2; . . . CnFn C1; C2; . . . CnEsc _[1x
```

Where *fn* is the non-shifted function key number, *Fn* is the shifted function key number and C1, C2 . . . C*n* are the character string values in ASCII Hex notation ("A" = 41, "B" = 42, etc.).

For example,

```
Esc [0xf1; 48H; 45H; 4CH; 4CH; 4FHf2; 12Hf3; 13Hf4; 14Hf5; 15HF1; 06HF2; 07HF3; 08HF4; 09HF5; 0AH Esc _[1x
```

In the above example, the non-shifted F1 contains the hex equivalent of the character string "STOP." The remaining functions keys contain their default values.

Custom Character Commands









The 80 Series' firmware changes some of the standard default characters from the display manufacturer display font tables and uses these characters as indicators for special functions. In the U.S. and Latin 1 display font tables, these standard default character locations are blank

If you do not require or wish to make use of these indicators, you can change their appearance. These custom characters (referred to a C1-C8), reside in the display character table at position 81h-88h (see [Table 5-2](#)).

Characters C1 and C2 are not used by the terminal and always available for reprogramming. Character 3 is the character displayed when receiving a backslash (5Ch) from the host or echoed from the keypad. Character C4 is the symbol displayed when a parity error occurs. Characters C5 through C8 are cursors characters that indicate the CTRL and/or SHIFT state.

To display these characters, you must first set the Data Bits parameter to 8 and enable Echo. You can then program a function key to output the characters. For example, to program the F1 key to display Character C1, you would define the key output value as a Hex 81.

Table 5-2: Programmable Characters

Character #	Symbol	Hex Value	Description	Character #	Symbol	Hex Value	Description
C1		81	Small Box	C5		85	Block Cursor
C2		82	Small Rectangle	C6		86	CTRL Indicator
C3		83	ASCII Backslash	C7		87	CTRL, SHIFT Indicator
C4		84	Parity Error	C8		88	SHIFT Indicator

Display Standard Characters

Syntax Esc [2v

Use this command to access the standard Two Technology's programmable characters in Hex locations 80 - 9F (see [Table 5-2](#)).

Display Manufacturer Characters

Syntax Esc [3v

Notes Use this command to access the characters originally specified by the display manufacturer for characters in Hex locations 80 - 9F.

When using the Latin 1 character set:

- Hex Location C5 will display a backslash (\)
- Hex Location 7F is the delete function (displays a blank)

When using the European character set:

- Hex Location 8B will display a lowercase o circumflex (ô)
- Hex Location 96 will display a lowercase e acute (é)
- Hex Location B0 will display a half symbol (½)

When using either the Latin 1 or European character set:

- Hex Location FE will display a lowercase thorn (þ)

Program Custom Character

Syntax Esc [5z Cn; R1; R2; . . . R8 Esc [0z

Notes Use this command to create a 5-pixel by 8-pixel display character, where Cn is the character number defined in Table 5-2 and R1; R2; . . . R8 are the row numbers of the character grid. Each row number consists of two hex values that when concatenated and converted to binary will turn the pixels in the row on or off (for example, a 1Fh = 00011111). This command is case sensitive.

The right most column of the matrix is always Bit 0. The values in three left most columns (Bits 5, 6 and 7) are ignored. Any omitted row bytes will default to zero.

Example To program Character C1 as a large rectangle, you would enter:

Esc [5z C1; 1F; 11; 11; 11; 11; 11; 1F; 00 Esc [0z

Bits	7	6	5	4	3	2	1	0	Hex
R1	0	0	0	1	1	1	1	1	1F
R2	0	0	0	1	0	0	0	1	11
R3	0	0	0	1	0	0	0	1	11
R4	0	0	0	1	0	0	0	1	11
R5	0	0	0	1	0	0	0	1	11
R6	0	0	0	1	0	0	0	1	11
R7	0	0	0	1	0	0	0	1	11
R8	0	0	0	1	1	1	1	1	1F

Legend:  Bit on,  Bit off,  Bit ignored

Power Saver Commands

Battery-powered terminals have a built-in power saver to conserve battery use during periods of inactivity. The power saver monitors keyboard activity. After eight minutes of inactivity, the terminal will begin to sound short warning beeps spaced twenty seconds apart. Any key press or character received from the host during this time will reset the Power Saver Timer. However, twenty seconds after the fifth, the terminal will shut itself down.

To prevent the possibility of storing erroneous data, the terminal will not save any changes made to parameter or function key data in the nonvolatile memory while the low-battery indicator is illuminated.

Disable Power Saver

Syntax Esc [8v

Notes Use this command to disable the Auto Shut Down feature.

Power Off

Syntax Esc [9v

Notes Use this command to turn off the terminal.

Advanced Control Mode

For line-powered units, Advanced Control Mode (ACM) enables you to restrict the input and output of the terminal's keypad by assigning specific hex values to each key press and each subsequent key release, making it ideal to control devices or applications in environments where safety is a primary concern.

While in ACM, the following terminal features and functions are affected:

- **Terminal Parameters** – to use ACM, you must ensure that the Data Bits parameter is set to eight data bits.

While in ACM mode, terminal echo and key repeat are disabled.

You cannot save ACM settings. If power is lost, the terminal will revert to Normal mode.

- **Menu Access** – access to the Parameter Setup menu, the Key Output Definition Setup menu and Contrast Control is disabled.
- **ENQ Acknowledgement** – when the host enables ACM, the terminal's response to an ENQ (05h) becomes a DLE (10h) instead of an ACK (06h). This response will enable the host to verify that the terminal is in ACM.

The host should then periodically check for DLE at a fixed time interval as required for your application (such as 25 ms) to verify ACM and connection of the terminal. Communication must be set to eight data bits.

- **Key Codes** – while in ACM, the terminal makes a distinction between a key press and key release when transmitting data to the host.

For key presses, the terminal sends the default hex value of the key (i.e., A = 41h, B = 42h, etc.). Any keys redefined in Normal (non-ACM) mode will return to their default settings until the suspension of ACM activities.

For key releases, the terminal adds a hex value of 80 to the default hex value (i.e., A = 41h + 80h = C1, B = 42h + 80h = C2, etc.).

For example, pressing F1 sends 11h, while releasing F1 sends a 91h.

- **nKey Rollover** – while in ACM, you can press any combination of keys in any order, and the terminal will send the resultant key codes in tandem (i.e., pressing CTRL, SHIFT and F1 will send 11h, 7Ch, and 5Ch) and then the corresponding key codes in tandem, when you release the keys (91h, FCh, and DCh).

However, if a combination of three pressed keys results in a pressed key sharing a common column or row with another pressed key (i.e., form a corner), the terminal will not transmit the resulting key codes because the matrix system used by the terminal for key detection will find a "Ghost" key as illustrated below:

Figure 5-1: Ghost Key

F1	F2	F3	F4	F5
+	()	<	>	
A	B	C	D	E
-	!	_	[]
F	G	H	I	J
/	&	:	;	?
K	L	M	N	
*	@	7	8	9
P	Q			
=	#	4	5	6
R	\$	1	2	3
^	%			
T	U			
.	%	.	0	CTRL
V	W	X		
*	ESC	BACKSP	ENTER	SHIFT
Y	Z	SPACE		

- **Modifier Keys** – while in ACM, the **CTRL** and **SHIFT** keys will not work as modifier keys; they can only change the mode indicator on the display as shown in the table below.

Table 5-3: ACM Mode– SHIFT and CTRL Key Results

<i>Command</i>	<i>Function</i>	<i>Key</i>	<i>Indicator</i>	<i>Press</i>	<i>Release</i>
Esc [4v	Disabled	SHIFT	None	5C	DC
	Disabled	CTRL	None	7C	FC
Esc [5v	Enabled	SHIFT	⦿	5C	DC
	Disabled	CTRL	None	7C	FC
Esc [6v	Disabled	SHIFT	None	5C	DC
	Enabled	CTRL	⦿	7C	FC
Esc [7v	Enabled	SHIFT	⦿	5C	DC
	Enabled	CTRL	⦿	7C	FC
	Enabled	CTRL, SHIFT	⦿	5C, 7C	DC ,FC

ACM Control Commands

Only the host can enable/disable ACM.

Because the host can send a request for ACM at any time, even while the operator is pressing or releasing keys, you should ensure that the host receives all keys press codes, their corresponding release codes and the proper ENQ response prior to any mode change.

Enable ACM

Syntax Esc [1v

Disable ACM

Syntax Esc [21v

Shift and Ctrl Key Control Commands

Disable Shift, Disable Ctrl

Syntax Esc [4v

Enable Shift, Disable Ctrl

Syntax Esc [5v

Disable Shift, Enable Ctrl

Syntax Esc [6v

Enable Shift, Enable Ctrl

Syntax Esc [7v

Example: Using ACM in a Robotic Environment

The following example shows the use of ACM in an industrial environment where safety during operation is a primary concern. A flowchart (Figure 5-3) appears on the following page

In this scenario, the terminal controls a robotic free-swinging arm (Figure 5-2), where:

1. The host transmits an ENQ (05h) every 25 ms to the terminal to determine its state (Normal mode or ACM).
2. The terminal in response will either send an ACK (06h) to indicate Normal mode or a DLE (10h) to indicate ACM. If no response is received, the host will stop the robotic arm.
3. In Normal mode, you can perform operations such as displaying graphics and switching to ACM (Esc [1v).
4. In ACM, you can press a key to move the arm and release a key to stop the arm. You can also switch back to Normal mode (Esc [21v).

Figure 5-2: Using ACM in a Robotic Environment

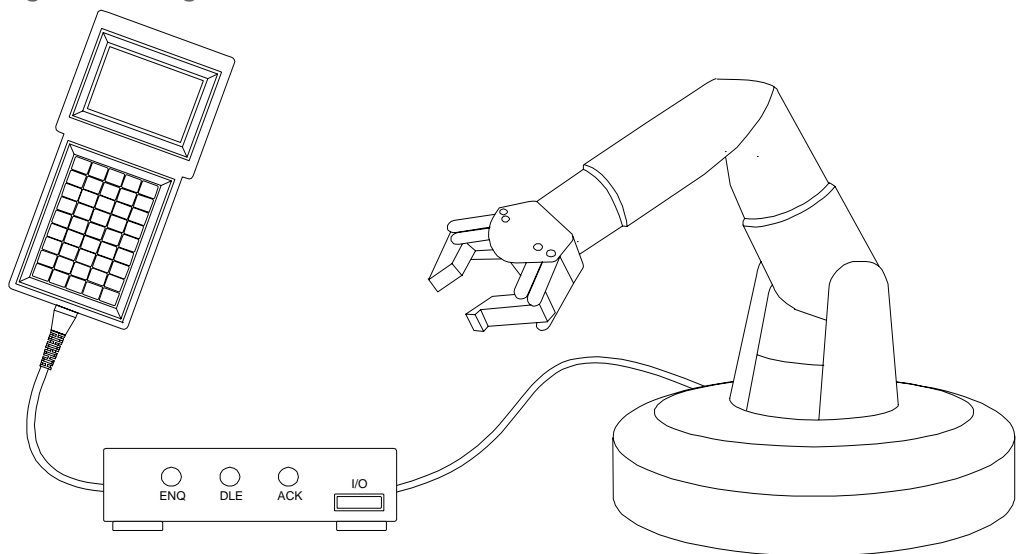
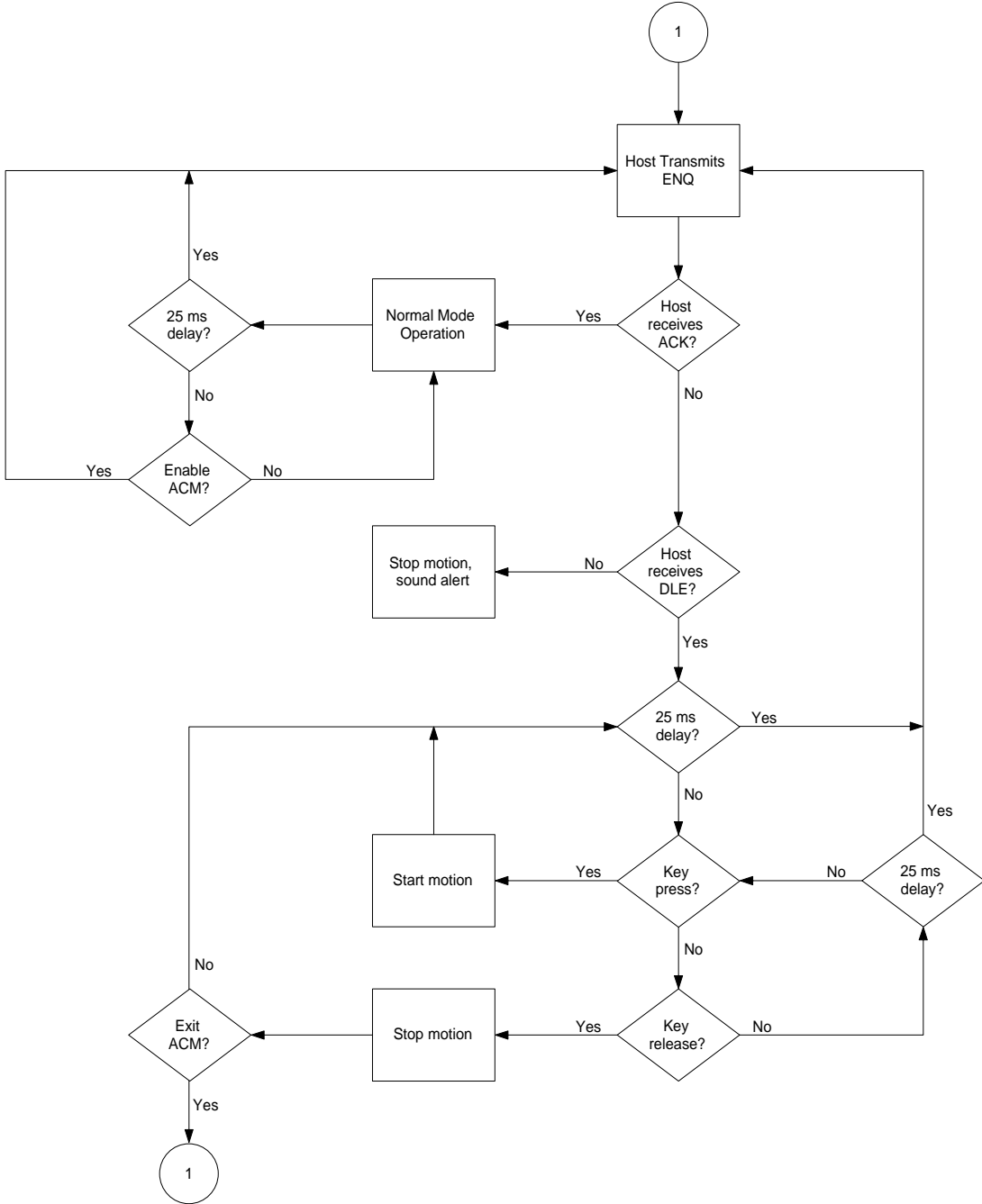

Figure 5-3: Using ACM in a Robotic Environment Flowchart



ANSI Mode Host Command Summary

The following table is a summary of the available ANSI mode host commands.

Table 5-4: ANSI Mode Host Command Summary

<i>Type</i>	<i>Command</i>	<i>Syntax</i>
Cursor	Cursor Up	Esc [<i>Pn</i> A
	Cursor Down	Esc [<i>Pn</i> B
	Cursor Right	Esc [<i>Pn</i> C
	Cursor Left	Esc [<i>Pn</i> D
	Cursor Position	Esc [<i>Pr</i> , <i>Pc</i> f or Esc [<i>Pr</i> , <i>Pc</i> H
	Cursor Home	Esc [f or Esc [H
	Cursor Home & Clear Display	Esc [1s
	Save Cursor Position	Esc [s
	Restore Cursor Position	Esc [u
	Enable Cursor	Esc [4t
	Disable Cursor	Esc [5t
	Enable Cursor Blink	Esc [6t
	Disable Cursor Blink	Esc [7t
Erasure	Erase Cursor to End of Line	Esc [K
	Erase Start of Line to Cursor	Esc [1K
	Erase Entire Line	Esc [2K
	Erase Cursor to End of Display	Esc [J
	Erase Start of Display to Cursor	Esc [1J
	Erase Entire Display	Esc [2J
Sound	Short Bell	Esc [0q
	Long Bell	Esc [1q
	Alert	Esc [2q
	Key Click	Esc [3q
Display Attributes	Set Blink Attribute	Esc [2s
	Clear Blink Attribute	Esc [3s
	Adjust LCD Contrast	Esc [v
	Enable Backlight ¹	Esc [8t
	Disable Backlight ¹	Esc [9t
Reports	Perform Self-Test & Return Results	Esc [4n
	Return Last Self-Test Results	Esc [5n
	Return Cursor Position	Esc [6n
	Send Device Attributes	Esc [c
	Send Identifier String	Esc [p

<i>Type</i>	<i>Command</i>	<i>Syntax</i>
Key	Enable Key Repeat	Esc [?8h
	Disable Key Repeat	Esc [?8l
	Enable Key Click	Esc [0t
	Disable Key Click	Esc [1t
	Enable KNP Function	Esc [2t
	Disable KNP Function	Esc [3t
LED Control ²	LED 1 Off	Esc [6q
	LED 1 On	Esc [7q
	LED 2 Off	Esc [8q
	LED 2 On	Esc [9q
	LED 3 Off	Esc [10q
	LED 3 On	Esc [11q
	LED 4 Off	Esc [12q
	LED 4 On	Esc [13q
	All Off	Esc [16q
Escape Mode	Switch to Private Mode	Esc [?2l
CR/LF Mode	Normal Mode	Esc [20l
	New Line Mode	Esc [20h
Parameter Modification	Set Parameters	Esc [1z P1; . . . Esc [0z
	Set and Save Parameters	Esc [2z P1; . . . Esc [0z
	Set Defaults	Esc [3z Esc [0z
Program Keys	Report Function Key Settings	Esc [4z Esc [0z
	Program Function Keys	Esc [5z <i>fn</i> <i>Fn</i> ; C1; . . . C20 Esc [0z
Custom Characters	Program Custom Character	Esc [5z <i>Cn</i> ; R1; . . . R8 Esc [0z
	Display Standard Characters	Esc [2v
	Display Manufacturer Characters	Esc [3v
Power ³	Disable Power Saver	Esc [8v
	Power Off	Esc [9v
Advance Control Mode ⁴	Enable ACM	Esc [1v
	Disable ACM	Esc [21v
	Disable SHIFT and CTRL	Esc [4v
	Enable SHIFT and Disable CTRL	Esc [5v
	Disable SHIFT and Enable CTRL	Esc [6v
	Enable SHIFT and CTRL	Esc [7v

1. Only if the terminal has an optional backlit display

2. Only if the terminal has optional LEDs

3. Battery-powered units only.

4. Line-powered units only.



Chapter 6: Private Host Commands

Introduction

As previously discussed, the terminal's design allows a host to control its functions by sending Escape commands. When set to Private mode, the terminal will recognize the simple compact command set discussed in this chapter. For example, sending an Esc H (Hex 1B 48) will move the cursor to the home position. A command summary appears at the end of this chapter.

Note: Do not use spaces between characters in Escape commands. Any spacing shown for Escape commands in this chapter is for clarity only unless otherwise noted.

Cursor Commands

Cursor Up

Syntax Esc A

Notes This command moves the cursor up one position. The cursor will not move beyond the start or end of a line, nor will it scroll the display.

Cursor Down

Syntax Esc B

Notes This command moves the cursor down one position. The cursor will not move beyond the start or end of a line, nor will it scroll the display.

Cursor Right

Syntax Esc C

Notes This command moves the cursor one position to the right. The cursor will not move beyond the start or end of a line, nor will it scroll the display.

Cursor Left

Syntax Esc D

Notes This command moves the cursor one position to the right. The cursor will not move beyond the start or end of a line, nor will it scroll the display.

Cursor Home & Clear Display

Syntax Esc E

Enable Cursor

Syntax Esc F

Disable Cursor

Syntax Esc G

Cursor Home

Syntax Esc H

Enable Blinking Cursor

Syntax Esc R

Disable Blinking Cursor

Syntax Esc S

Cursor Position

Syntax Esc Y *Pr Pc*

Notes This command moves the cursor to a specified location where *Pr* is the ASCII character equivalent of the row numbers and *Pc* is the ASCII character equivalent of the column numbers shown below.

<i>Row</i>	<i>ASCII</i>
1	SP
2	!
3	"
4	#
5	\$
6	%
7	@
8	'
9	(
10)
11	*
12	+
13	,
14	-
15	.
16	/

<i>Column</i>	<i>ASCII</i>	<i>Column</i>	<i>ASCII</i>
1	SP	17	0
2	!	18	1
3	"	19	2
4	#	20	3
5	\$	21	4
6	%	22	5
7	&	23	6
8	'	24	7
9	(25	8
10)	26	9
11	*	27	:
12	+	28	;
13	,	29	<
14	-	30	=
15	.	31	>
16	/	32	?

Examples Esc Y !) Sends the cursor to Row 2, Column 10
Esc Y % 0 Sends the cursor to Row 6, Column 17
Esc Y / ? Sends the cursor to Row 16, Column 32

Erase Commands

Erase Cursor to End of Line

Syntax Esc K

Notes Includes the character at the cursor location and does not alter the cursor position

Erase Cursor to End of Display

Syntax Esc J

Notes Includes the character at the cursor location and does not alter the cursor position

Erase Entire Line

Syntax Esc M

Notes Includes the character at the cursor location and does not alter the cursor position

Erase Display and Home Cursor

Syntax Esc E

Display Attribute Commands

Set Blink Attribute

Syntax Esc W

Notes Enables characters on the display to blink. Characters written subsequent to the setting or clearing of attributes will assume the new attribute characteristics.

Clear Blink Attribute

Syntax Esc X

Notes Stop characters on the display from blinking. Characters written subsequent to the setting or clearing of attributes will assume the new attribute characteristics.

Adjust LCD Contrast

Syntax Esc I

Notes This command increases the contrast one level

Enable Backlight

Syntax Esc n

Notes Applies only to terminals with optional backlit displays

Disable Backlight

Syntax Esc f

Notes Applies only to terminals with optional backlit displays

Sound Commands

Note: You cannot buffer sound commands. To produce properly spaced chain sounds, the host must delay a short time between issuing sound commands.

Short Bell

Syntax Esc T

Long Bell

Syntax Esc L

Alert

Syntax Esc Q

Escape Mode Commands

Switch to ANSI Mode

Syntax Esc <

Notes This command causes the terminal to switch from recognizing Private host commands to recognizing ANSI host commands.

Key Attribute Commands

Enable Key Click

Syntax Esc U

Disable Key Click

Syntax Esc V

Enable KNP Function

Syntax Esc N

Disable KNP Function

Syntax Esc O

Return Commands

Return Terminal Identifier String

Syntax Esc Z

Notes This command sends the following identifier string to the host:

Esc [0x 80*NN* *CCCC* Esc [1x

Where *NN* is the keypad type (20, 30 or 45) and *CCCC* is the four-byte hexadecimal checksum of the terminal's program memory.

When using this command to identify the terminal type, do not include the checksum as it may change.

Private Mode Host Command Summary

The following table is a summary of the available Private mode host commands.

Table 6-1: Private Mode Host Command Summary

<i>Type</i>	<i>Command</i>	<i>Syntax</i>
Cursor	Cursor Up	Esc A
	Cursor Down	Esc B
	Cursor Right	Esc C
	Cursor Left	Esc D
	Cursor Home & Clear Display	Esc E
	Enable Cursor	Esc F
	Disable Cursor	Esc G
	Cursor Home	Esc H
	Enable Blinking Cursor	Esc R
	Disable Blinking Cursor	Esc S
	Cursor Position	Esc Y Pr Pc
Erasure	Erase Cursor to End of Line	Esc K
	Erase Cursor to End of Display	Esc J
	Erase Entire Line	Esc M
	Erase Display and Home Cursor	Esc E
Escape Mode	Switch to ANSI Mode	Esc <
Key Attributes	Enable Key Click	Esc U
	Disable Key Click	Esc V
	Enable KNP Function	Esc N
	Disable KNP Function	Esc O
Sound	Short Bell	Esc T
	Long Bell	Esc L
	Alert	Esc Q
Return	Return Terminal Identifier String	Esc Z
Display Attributes	Set Blink Attribute	Esc W
	Clear Blink Attribute	Esc X
	Adjust LCD Contrast	Esc I
	Enable Backlight ¹	Esc n
	Disable Backlight ¹	Esc f

1. Only if the terminal has an optional backlit display



Chapter 7: Control Codes

In addition to ANSI and Private mode commands, the terminal will also respond to the following control codes:

Table 7-1: Control Codes

<i>Code</i>	<i>Hex</i>	<i>Dec.</i>	<i>ASCII</i>	<i>Function</i>
Ctrl E	05	5	ENQ	Enquire
Ctrl G	07	7	BEL	Sounds Bell
Ctrl H	08	8	BKSP	Back Space Cursor
Ctrl J	0A	10	LF	Line Feed
Ctrl K	0B	11	VT	Cursor Down
Ctrl M	0D	13	CR	Cursor Left to Column 1
DEL	7F	127	DEL	Delete Character at Cursor

Note: When the host transmits a Ctrl E, the terminal will respond with either an ACK (ANSI or Private Mode) or a DLE (ACM mode).



Chapter 8: Troubleshooting

Cursor does not appear on display

Possible Cause: No power to terminal (host supplied)

Solution: Verify proper voltage to terminal

Possible Cause: No power to terminal (adapter supplied)

Solution: Verify wall plug is functional and wiring of adapter (if wired as kit)

Possible Cause: Reversed polarity, improper wiring or wrong cable type

Solution: Check cable and connector wiring

Possible Cause: Cursor not enabled

Solution: Re-enable the cursor by sending an Esc [4t (ANSI mode) or Esc F (Private mode) or by changing the CURSOR parameter setting

Terminal resets or locks-up

Possible Cause: Low supply voltage

Solution: Verify proper voltage to terminal

Possible Cause: Cable resistance too high or wire gauge too small

Solution: If cable is 26 AWG, the length should not exceed 15 feet

If a longer length cable is required, use a thicker gage cable

Possible Cause: Handshaking between host and terminal

Solution: When using handshaking, verify that the wiring between the host and terminal is correct, that you have the HANDSHAKE parameter enabled and that the handshake line from the host is asserted

When not using handshaking, make sure you have the HANDSHAKE parameter disabled

Terminal not receiving or displaying correct characters

Possible Cause: Parity settings incorrect

Solution: Change PARITY parameter to correct setting

Possible Cause: Data bits incorrect

Solution: Change DATA BITS parameter to correct setting

Possible Cause: Incorrect BAUD rate

Solution: Change BAUD parameter to correct setting

Possible Cause: Handshaking between host and terminal

Solution: When using handshaking, verify that the wiring between the host and terminal is correct, that you have the HANDSHAKE parameter enabled and that the handshake line from the host is asserted

When not using handshaking, make sure you have the HANDSHAKE parameter disabled

Possible Cause: Reversed polarity, improper wiring or wrong cable type

Solution: Check cable and connector wiring

Terminal displays PE character

Possible Cause: Incorrect parity setting

Solution: Change the PARITY setting on the terminal to match the host or vice versa

Possible Cause: Handshaking between host and terminal

Solution: When using handshaking, verify that the wiring between the host and terminal is correct, that you have the HANDSHAKE parameter enabled and that the handshake line from the host is asserted

When not using handshaking, make sure you have the HANDSHAKE parameter disabled

Terminal generates continuous sound while pressing key

Possible Cause: Handshaking between host and terminal

Solution: When using handshaking, verify that the wiring between the host and terminal is correct, that you have the HANDSHAKE parameter enabled and that the handshake line from the host is asserted

When not using handshaking, make sure you have the HANDSHAKE parameter disabled

Terminal displays double characters

Possible Cause: Echo turned on

Solution: Disable ECHO parameter

Terminal does not perform self-test

Possible Cause: Self-test parameter disabled

Solution: Change SELF TEST parameter to ENABLED

Cannot access parameter mode or function key programming

Possible Cause: Menu lock-out enabled

Solution: Remove power, simultaneously hold **CTRL**, **SHIFT** and **F3**, and reapply power

Possible Cause: Handshaking between host and terminal

Solution: When using handshaking, verify that the wiring between the host and terminal is correct, that you have the HANDSHAKE parameter enabled and that the handshake line from the host is asserted

When not using handshaking, make sure you have the HANDSHAKE parameter disabled

Terminal losing characters

Possible Cause: Handshaking between host and terminal

Solution: When using handshaking, verify that the wiring between the host and terminal is correct, that you have the HANDSHAKE parameter enabled and that the handshake line from the host is asserted

When not using handshaking, make sure you have the HANDSHAKE parameter disabled

Key does not repeat when pressed

Possible Cause: Repeat parameter disabled

Solution: Change repeat parameter to either SLOW, MEDIUM or FAST

Function keys not sending correct values

Possible Cause: Key accidentally reprogrammed

Solution: Reprogram function key

Possible Cause: EEPROM corrupted by line disturbance

Solution: Restore factory defaults and then reprogram parameters and function keys

Possible Cause: Terminal reset to factory defaults after repair

Solution: Reprogram function keys



Appendix A: Specifications

<p>Display</p> <ul style="list-style-type: none"> ▶ Standard: Reflective/Transreflective Liquid Crystal Display, 4 Rows of 20 (5 x 7 pixel) characters ▶ Extended U.S. ASCII character set, Dark Characters on Light Background (except VFD) ▶ Menu-Controlled Contrast Settings ▶ Optional Displays: Supertwist Nematic, Backlit Supertwist Nematic, Extended Temperature Backlit, Vacuum Fluorescent Displays (VFD¹ and Extended Temperature VFD¹) <p>Not available on battery-powered units.</p>
<p>Keys & Switches</p> <ul style="list-style-type: none"> ▶ Type: Membrane or Elastomeric ▶ Standard Layouts: 45-key (9 rows x 5 columns), 30-key (6 x 5) and 20-key (5 x 4) ▶ Custom Layouts: 32-key (8 x 4) and 15-key (5 x 3) ▶ Feedback: Tactile and Audible ▶ Programmability: Five Function Keys with Fifteen Definitions ▶ Options: <ul style="list-style-type: none"> ▪ Emergency Stop: 2 Pole "Press and Twist," Contact Rating: 0.5 A, 28 VDC ▪ Backlit Keypad
<p>Power</p> <ul style="list-style-type: none"> ▶ Voltage: 5 VDC +/- 5%, 7.5-12 VDC¹ Linear Regulator or 9.5-28 VDC Switching Regulator ▶ Current: 15-20 mA Nominal (RS-232, RS-422)² <p>1. Maximum voltage depends on current draw. 2. Some options require additional current (for example, a backlight adds 50 mA)</p>
<p>CPU</p> <ul style="list-style-type: none"> ▶ Type: Atmel AT89C55WD ▶ Speed: 11.059 MHz
<p>Interface</p> <ul style="list-style-type: none"> ▶ Type: RS-232, RS-422 or CMOS/LSTTL level ▶ Handshaking: 2 Lines (DTR, DTS) for RS-232, CMOS/LSTTL ▶ Data Rates: 300 to 19,200 bps (9,600 and above requires handshaking) ▶ Parity Range: Even, Odd, Mark, Space, None, Ignore ▶ Control Bits: 1 Start and 1-2 Stop Bits ▶ Interface Connector: 6 Pin Modular

Environmental

- ▶ Nematic Displays
 - Storage Temperature: -20°C to +70°C,
 - Operating Temperature: Standard: 0° to + 50°C, Extended Temperature: -20°C to +70°C
- ▶ Vacuum Fluorescent Displays
 - Storage Temperature: -40° to + 85°C
 - Operating Temperature: Standard: -20° to + 70°C, Extended Temperature: -40° to + 85°C
- ▶ Humidity: 5-95% (Non-condensing) Humidity: 5-95% (non-condensing)

Physical

- ▶ Height: 8.25.inches (209.6 mm)
- ▶ Width: 4.10 inches (104.1 mm)
- ▶ Depth: 1.15 inches (29.2 mm)
- ▶ Weight: 8 ounces (227 grams)
- ▶ Weight w/NiMH Battery: 18 ounces (510 grams)
- ▶ Case: General Electric Cyclac ABS

Specifications are subject to change without notice

Figure A-1: 80 Series Terminal Case Dimensions

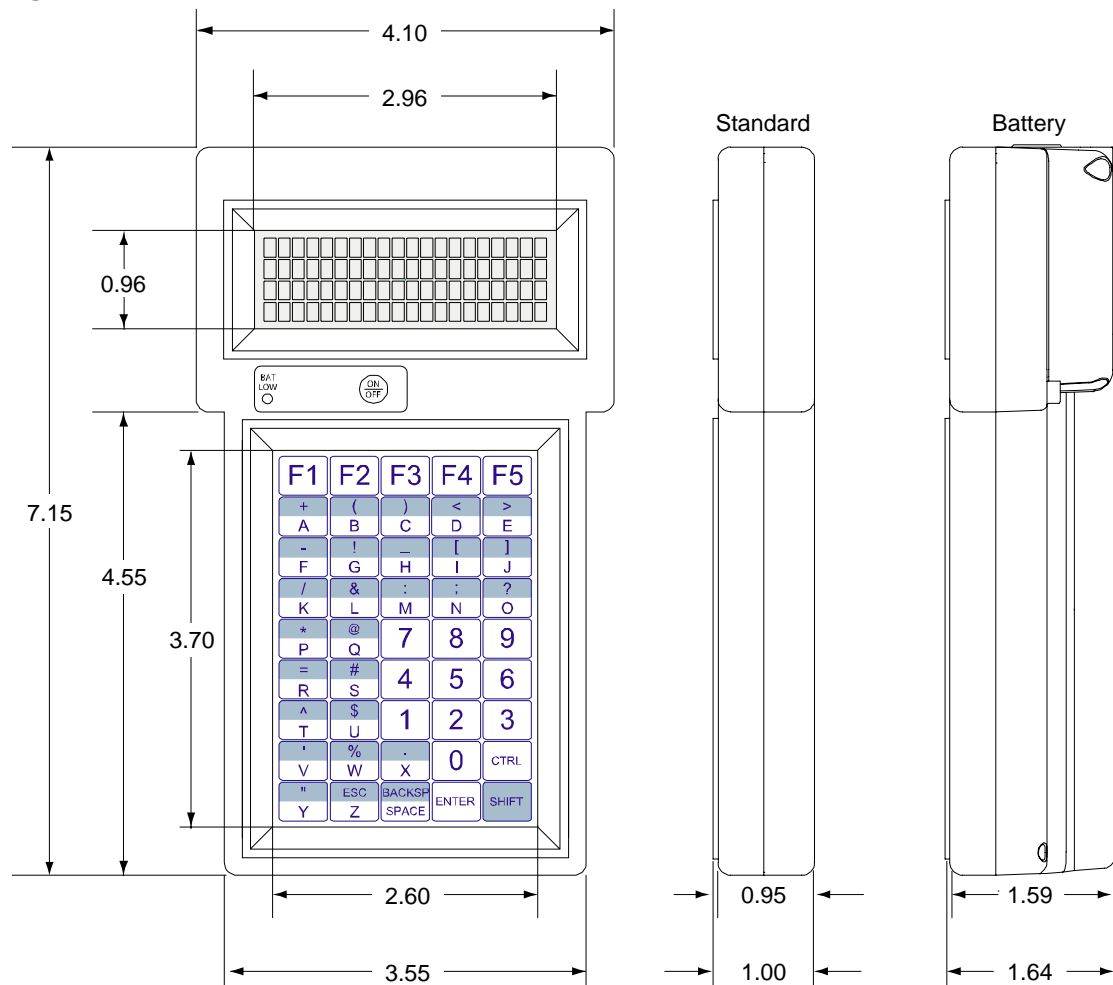



Appendix B: ASCII Character Set

Introduction

The following table contains the 80 Series ASCII character set and corresponding Decimal, Hex and Binary conversion codes as well as the keystroke entry for QWERTY style PC keyboards:

Table B-1: ASCII Character Set and Conversion Codes

<i>ASCII</i>	<i>Decimal</i>	<i>HEX</i>	<i>Binary</i>	<i>PC Key</i>	<i>ASCII</i>	<i>Decimal</i>	<i>HEX</i>	<i>Binary</i>	<i>PC Key</i>
NUL	0	00	00000000	CTRL 1	RS	30	1E	00011110	CTRL =
SOH	1	01	00000001	CTRL A	US	31	1F	00011111	CTRL -
STX	2	02	00000010	CTRL B	Space	32	20	00100000	Space
ETX	3	03	00000011	CTRL C	!	33	21	00100001	!
EOT	4	04	00000100	CTRL D	"	34	22	00100010	"
ENQ	5	05	00000101	CTRL E	#	35	23	00100011	#
ACK	6	06	00000110	CTRL F	\$	36	24	00100100	\$
BEL	7	07	00000111	CTRL G	%	37	25	00100101	%
BS	8	08	00001000	CTRL H	&	38	26	00100110	&
HT	9	09	00001001	CTRL I	'	39	27	00100111	'
LF	10	0A	00001010	CTRL J	(40	28	00101000	(
VT	11	0B	00001011	CTRL K)	41	29	00101001)
FF	12	0C	00001100	CTRL L	*	42	2A	00101010	*
CR	13	0D	00001101	CTRL M	+	43	2B	00101011	+
SO	14	0E	00001110	CTRL N	,	44	2C	00101100	,
SI	15	0F	00001111	CTRL O	-	45	2D	00101101	-
DLE	16	10	00010000	CTRL P	.	46	2E	00101110	.
DC1	17	11	00010001	CTRL Q	/	47	2F	00101111	/
DC2	18	12	00010010	CTRL R	0	48	30	00110000	0
DC3	19	13	00010011	CTRL S	1	49	31	00110001	1
DC4	20	14	00010100	CTRL T	2	50	32	00110010	2
NAK	21	15	00010101	CTRL U	3	51	33	00110011	3
SYNC	22	16	00010110	CTRL V	4	52	34	00110100	4
ETB	23	17	00010111	CTRL W	5	53	35	00110101	5
CAN	24	18	00011000	CTRL X	6	54	36	00110110	6
EM	25	19	00011001	CTRL Y	7	55	37	00110111	7
SUB	26	1A	00011010	CTRL Z	8	56	38	00111000	8
ESC	27	1B	00011011	ESC	9	57	39	00111001	9
FS	28	1C	00011100	CTRL<	:	58	3A	00111010	:
GS	29	1D	00011101	CTRL	;	59	3B	00111011	;

<i>ASCII</i>	<i>Decimal</i>	<i>HEX</i>	<i>Binary</i>	<i>PC Key</i>	<i>ASCII</i>	<i>Decimal</i>	<i>HEX</i>	<i>Binary</i>	<i>PC Key</i>
<	60	3C	00111100	<	W	87	57	01010111	W
=	61	3D	00111101	=	X	88	58	01011000	X
@	64	40	01000000	@	Y	89	59	01011001	Y
A	65	41	01000001	A	Z	90	5A	01011010	Z
B	66	42	01000010	B	[91	5B	01011011	[
C	67	43	01000011	C	\	92	5C	01011100	\
D	68	44	01000100	D]	93	5D	01011101]
E	69	45	01000101	E	^	94	5E	01011110	^
F	70	46	01000110	F	_	95	5F	01011111	_
G	71	47	01000111	G	`	96	60	01100000	`
H	72	48	01001000	H	a	97	61	01100001	a
I	73	49	01001001	I	b	98	62	01100010	b
J	74	4A	01001010	J	c	99	63	01100011	c
K	75	4B	01001011	K	d	100	64	01100100	d
L	76	4C	01001100	L	e	101	65	01100101	e
M	77	4D	01001101	M	f	102	66	01100110	f
N	78	4E	01001110	N	g	103	67	01100111	g
O	79	4F	01001111	O	h	104	68	01101000	h
P	80	50	01010000	P	i	105	69	01101001	i
A	65	41	01000001	A	j	106	6A	01101010	j
B	66	42	01000010	B	k	107	6B	01101011	k
C	67	43	01000011	C	l	108	6C	01101100	l
D	68	44	01000100	D	m	109	6D	01101101	m
E	69	45	01000101	E	n	110	6E	01101110	n
F	70	46	01000110	F	o	111	6F	01101111	o
G	71	47	01000111	G	p	112	70	01110000	p
H	72	48	01001000	H	q	113	71	01110001	q
I	73	49	01001001	I	r	114	72	01110010	r
J	74	4A	01001010	J	s	115	73	01110011	s
K	75	4B	01001011	K	t	116	74	01110100	t
L	76	4C	01001100	L	u	117	75	01110101	u
M	77	4D	01001101	M	v	118	76	01110110	v
N	78	4E	01001110	N	w	119	77	01110111	w
O	79	4F	01001111	O	x	120	78	01111000	x
P	80	50	01010000	P	y	121	79	01111001	y
Q	81	51	01010001	Q	z	122	7A	01111010	z
R	82	52	01010010	R	{	123	7B	01111011	{
S	83	53	01010011	S		124	7C	01111100	
T	84	54	01010100	T	}	125	7D	01111101	}
U	85	55	01010101	U	→	126	7E	01111110	
V	86	56	01010110	V	Delete	127	7F	01111111	



Appendix C: Font Tables

Standard Display Font Table

The following table contains the Standard font characters displayed by 80 Series terminals:

Table C-1: Standard Display Font Table

HEX	2X	3X	4X	5X	6X	7X	8X	9X	AX	BX	CX	DX	EX	FX
X0		0	1	2	3	4				7	8	9	A	B
X1	.	1	A	0	a	9			.	7	8	9	A	B
X2	"	2	B	R	B	R			"	7	8	9	A	B
X3	#	3	C	S	c	s			#	7	8	9	A	B
X4	\$	4	D	T	t	T			\$	7	8	9	A	B
X5	%	5	E	U	u	U			%	7	8	9	A	B
X6	&	6	F	V	v	V			&	7	8	9	A	B
X7	'	7	G	W	w	W			'	7	8	9	A	B
X8	(8	H	X	x	X			(7	8	9	A	B
X9)	9	I	Y	y	Y)	7	8	9	A	B
XA	*	A	J	Z	z	Z			*	7	8	9	A	B
XB	+	B	K	[[[+	7	8	9	A	B
XC	,	C	L	\	\	\			,	7	8	9	A	B
XD	-	D	M]]]			-	7	8	9	A	B
XE	.	E	N	^	^	^			.	7	8	9	A	B
XF	/	F	O	_	_	_			/	7	8	9	A	B

Latin1 Display Font Table

The following table contains the Latin1 font characters displayed by 80 Series terminals:

Table C-2: Latin1 Display Font Table

HEX	2X	3X	4X	5X	6X	7X	8X	9X	AX	BX	CX	DX	EX	FX
X0		0	1	2	3	4				8	9	0	1	2
X1	.	l	A	B	a	m			l	*	A	R	a	m
X2	1	2	B	R	b	r	F		o	A	R	o	a	o
X3	H	3	C	S	s	N			l	S	A	C	a	o
X4	*	4	D	T	e	R			o	A	A	A	A	A
X5	Z	5	E	U	u	U			Y	U	A	o	a	o
X6	6	6	F	V	v	F			l	U	o	o	o	o
X7	7	7	G	W	w	G			S	A	S	X	S	+
X8	8	8	H	X	x	X			.	.	o	o	o	o
X9	9	9	I	Y	y	H			o	l	o	o	o	o
XA	*	*	J	Z	z	Z			S	S	o	o	o	o
XB	+	+	K	L	k	L			X	X	o	o	o	o
XC	.	.	L	N	l	l			T	N	Y	U	Y	U
XD	—	—	M	O	m	O			S	N	Y	Y	Y	S
XE	.	.	N	o	n	o			o	N	l	o	o	o
XF	/	?	O	o	o				—	o	l	l	l	U

European Display Font Table

The following table contains the European font characters displayed by 80 Series terminals:

Table C-3: European Display Font Table

HEX	2X	3X	4X	5X	6X	7X	8X	9X	AX	BX	CX	DX	EX	FX
X0		0	1	2	3	4	5	6	7	8	9	*	/	
X1	:	;	A	B	a	b	c	d	e	f	g	h	i	j
X2	"	#	\$	%	&	'	()	[]	^	_	~	°
X3	~	0	1	2	3	4	5	6	7	8	9	*	/	
X4	\$	%	&	'	()	[]	^	_	~	°	±	²
X5	z	5	E	U	u	U	U	e	i	4	0	7	8	9
X6	6	F	U	F	V	H	e	N	J	K	+	0	2	
X7	7	A	W	a	w	B	a	a	a	a	a	x	a	a
X8	C	E	H	K	h	X	T	h	N	N	N	N	T	0
X9	7	9	I	Y	i	6	0	a	9	*	0	1	2	3
XA	*	;	J	Z	j	Z	9	a	9	*	9	\	7	h
XB	+	;	K	E	K	K	6	a	v	*	a	x	m	m
XC	.	<	L	\	l	l	a	a	v	m	0	0	6	m
XD	—	=	N	J	n	7	6	a	W	N	0	0	0	0
XE	.	>	N	n	n	7	6	a	W	0	0	0	0	6
XF	/	?	0		a		z	a	0	N	6	6	m	0



Appendix D: Keypad Hex Output Values

45-Key Keypad Hex Output

The following table contains the hex output for a standard 45-key keypad, where “CS” is CTRL + SHIFT (Locked) key output, “C” is CTRL key output, “S” is SHIFT key output and “U” is single key output.

Table D-1: 45-Key Keypad Hex Output Values

Key = Hex CS1 = __ C1 ¹ = 1B 5B 41 S1 = 06 U1 = 11	Key = Hex CS10 = __ C10 ¹ = 1B 5B 42 S10 = 07 U10 = 12	Key = Hex CS19 = 13 C19 ¹ = 1B 5B 43 S19 = 08 U19 = 13	Key = Hex CS28 = 14 C28 ¹ = 1B 5B 44 S28 = 09 U28 = 14	Key = Hex CS37 = __ C37 ¹ = __ S37 = 0A U3 = 15
CS2 = 61 C2 = 01 S2 = 2B U2 = 41	CS11 = 62 C11 = 02 S11 = 28 U11 = 42	CS20 = 63 C20 = 03 S20 = 29 U20 = 43	CS29 = 64 C29 = 04 S29 = 3C U29 = 44	CS38 = 65 C38 = 05 S38 = 3E U38 = 45
CS3 = 66 C3 = 06 S3 = 2D U3 = 46	CS12 = 67 C12 = 07 S12 = 21 U12 = 47	CS1 = 68 C21 = 08 S21 = 5F U21 = 48	CS1 = 69 C30 = 09 S30 = 5B U30 = 49	CS1 = 6A C39 = 0A S39 = 5D U39 = 4A
CS4 = 6B C4 = 0B S4 = 2F U4 = 4B	CS13 = 6C C13 = 0C S13 = 26 U13 = 4C	CS22 = 6D C22 = 0D S22 = 3A U22 = 4D	CS31 = 6E C31 = 0E S31 = 3B U31 = 4E	CS40 = 6F C40 = 0F S40 = 3F U40 = 4F
CS5 = 70 C5 = 10 S5 = 2A U5 = 50	CS14 = 71 C14 = 11 S14 = 40 U14 = 51	CS23 = 37 C23 = __ S23 = 37 U23 = 37	CS32 = 38 C32 = __ S32 = 38 U32 = 38	CS41 = 39 C41 = __ S41 = 39 U41 = 39
CS6 = 72 C6 = 12 S6 = 3D U6 = 52	CS15 = 73 C15 = 13 S15 = 23 U15 = 53	CS24 = 34 C24 = __ S24 = 34 U24 = 34	CS33 = 35 C33 = __ S33 = 35 U33 = 35	CS42 = 36 C42 = __ S42 = 36 U42 = 36
CS7 = 74 C7 = 14 S7 = 5E U7 = 54	CS16 = 75 C16 = 15 S16 = 24 U16 = 55	CS25 = 31 C25 = __ S25 = 31 U25 = 31	CS32 = 32 C34 = __ S34 = 32 U34 = 32	CS43 = 33 C43 = __ S43 = 33 U43 = 33
CS8 = 79 C8 = 16 S8 = 2C U8 = 56	CS17 = 7A C17 = 17 S17 = 25 U17 = 57	CS26 = 20 C26 = 18 S26 = 2E U26 = 58	CS35 = 0D C35 = __ S35 = 30 U35 = 30	CTRL
CS9 = 79 C9 = 19 S9 = 22 U9 = 59	CS18 = 7A C18 = 1A S18 = 1B U18 = 5A	CS27 = 20 C27 = __ S27 = 08 U27 = 20	CS36 = 0D C36 = __ S36 = 0D U36 = 0D	SHIFT

1. While in Private mode, C1, C10, 19, C28 and C37 will not return a 5Bh (e.g., C1 = 1B 41, C2 = 1B 42, etc).

30-Key Keypad Hex Output

The following table contains the hex output for a standard 30-key keypad, where “CS” is CTRL + SHIFT (Locked) key output, “C” is CTRL key output, “S” is SHIFT key output and “U” is single key output.

Table D-2: 30-Key Keypad Hex Output Values

Key = Hex	Key = Hex	Key = Hex	Key = Hex	Key = Hex
CS1 = __ C1 = 01 S1 = 11 U1 = 41	CS7 = __ C7 = 02 S7 = 12 U7 = 42	CS13 = 63 C13 = 03 S13 = 13 U13 = 43	CS19 = 64 C19 = 04 S19 = 14 U19 = 44	CS25 = __ C25 = __ S25 = 15 U25 = 45
CS2 = 66 C2 = 06 S2 = 2F U2 = 46	CS8 = 67 C8 = 07 S8 = 28 U8 = 47	CS14 = 68 C14 = 08 S14 = 31 U14 = 48	CS20 = 69 C20 = 09 S20 = 32 U20 = 49	CS26 = 6A C26 = 0A S26 = 33 U26 = 4A
CS3 = 6B C3 = 0B S3 = 2A U3 = 4B	C9 = 6C C9 = 0C S9 = 29 U9 = 4C	CS15 = 6D C15 = 0D S15 = 34 U15 = 4D	CS21 = 6E C21 = 0E S21 = 35 U21 = 4E	CS27 = 6F C27 = 0F S27 = 36 U27 = 4F
CS4 = 70 CS4 = 10 S4 = 2D U4 = 50	CS10 = 71 C10 = 11 S10 = 23 U10 = 51	CS16 = 72 C16 = 12 S16 = 37 U16 = 52	CS22 = 73 C22 = 13 S22 = 38 U22 = 53	CS28 = 74 C28 = 14 S28 = 39 U28 = 54
CS5 = 75 CS5 = 15 S5 = 2B U5 = 55	CS11 = 76 C11 = 16 S11 = 2C U11 = 56	CS17 = 77 C17 = 17 S17 = 3D U17 = 57	CS23 = 78 C23 = 18 S23 = 30 U23 = 58	CS29 = 79 C29 = 19 S29 = 2E U29 = 59
CS6 = 7A C6 = 1A S6 = 1B U6 = 5A	CS12 = 20 C12 = __ S12 = 08 U12 = 20	CS18 = 0D C18 = __ S18 = 0D U18 = 0D	CTRL	SHIFT

20-Key Keypad Hex Output

The following table contains the hex output for a standard 20-key keypad:

Table D-3: 20-Key Keypad Hex Output Values

Key = Hex	Key = Hex	Key = Hex	Key = Hex
1 = 41	6 = 42	11 = 43	16 = 44
2 = 31	7 = 32	12 = 33	17 = 2B
3 = 34	8 = 35	13 = 36	18 = 2D
4 = 37	9 = 38	14 = 39	19 = __
5 = 2E	10 = 30	15 = 20	20 = __



Index

8

80 Series Terminal Features 1-2

A

About the 80 Series Terminal 1-2
 About this Manual 1-1
 About Two Technologies 1-1
 ACM Control Commands 5-13
 Adjust LCD Contrast 5-4, 6-3
 Advanced Control Mode 5-12
 Alert 5-3, 6-4
 ANSI 3.64/VT100 compatibility 5-5
 ANSI Mode 2-8
 ANSI Mode Host Command Summary 5-16

ANSI Mode Host Commands **5-1**

ASCII Character Set B-1
 Assert Handshake-Out Equals +V 4-6
 Assert Handshake-Out Equals -V 4-6

B

Backlight 3-5
 Baud Rate 3-1
 Branch to Function Key 4-6
 Branching Commands 4-5
 Break Commands 3-5, 4-3

C

Cable and Power Connections 2-2
 Cable Connections 2-4
 Case Dimensions A-2
 Changing Batteries 2-5
 Changing Parameter Settings 3-6
 Charging the Unit 2-5
 Clear Blink Attribute 5-4, 6-3
 Communication Parameters Accessibility 3-2
 Concatenate Function Key String 4-5
 Conditional Branch 4-6
 Connecting the Terminal 2-4
 Contrast Adjustment 2-7
 Control Codes 7-1

Controls and Indicators 2-1
 CPU Specifications A-1
 CR/LF Commands 5-2
 CR/LF Mode 3-4
 Current Draw vii
 Cursor 3-3
 Cursor Blink 3-3
 Cursor Commands 5-1, 6-1
 Cursor Down 5-1, 6-1
 Cursor Home 6-2
 Cursor Home & Clear Display 5-2, 6-1
 Cursor Left 5-1, 6-1
 Cursor Position 2-6, 5-2, 6-2
 Cursor Right 5-1, 6-1
 Cursor Up 5-1, 6-1
 Custom Character Commands 5-10

D

Data Bits 3-1
 DB-25 Interface Connector 2-2
 DB-25 Interface Connector Signal and Pin Assignments
 2-3
 Defining Function Keys 4-2
 Disable ACM 5-13
 Disable All LEDs 5-6
 Disable Backlight 5-4, 6-3
 Disable Blinking Cursor 6-2
 Disable Cursor 5-2, 6-2
 Disable Function Key Output 4-5
 Disable Key Click 5-4, 6-4
 Disable Key Repeat 5-4
 Disable KNP Function 5-4, 6-4
 Disable LED 1 5-6
 Disable LED 2 5-6
 Disable LED 3 5-6
 Disable LED 4 5-6
 Disable Power Saver 5-11
 Disable Shift, Disable Ctrl 5-13
 Disable Shift, Enable Ctrl 5-13
 Display 1-2, 2-1
 Display Attribute Commands 5-4, 6-3
 Display Manufacturer Characters 5-10
 Display Operation 2-6
 Display PE 3-2
 Display Specifications A-1

Display Standard Characters.....	5-10
Durability.....	1-2
E	
Echo.....	3-3
Enable ACM.....	5-13
Enable Backlight.....	5-4, 6-3
Enable Blinking Cursor.....	5-2, 6-2
Enable Cursor.....	5-2, 6-2
Enable Key Click.....	5-4, 6-4
Enable Key Repeat.....	5-4
Enable KNP Function.....	5-4, 6-4
Enable LED 1.....	5-6
Enable LED 2.....	5-6
Enable LED 3.....	5-6
Enable LED 4.....	5-6
Enable Shift, Disable Ctrl.....	5-13
Enable Shift, Enable Ctrl.....	5-13
Enable Steady Block Cursor.....	5-2
Environmental Specifications.....	A-2
Erase Cursor to End of Display.....	5-3, 6-3
Erase Cursor to End of Line.....	5-3, 6-3
Erase Display and Home Cursor.....	6-3
Erase Entire Display.....	5-3
Erase Entire Line.....	5-3, 6-3
Erase Start of Display to Cursor.....	5-3
Erase Start of Line to Cursor.....	5-3
Erasure Commands.....	5-3, 6-3
Escape Mode.....	3-3
Escape Mode Commands.....	5-2, 6-4
E-Stop Operation.....	2-7
E-Stop Switch Wiring.....	2-7
European Display Font Table.....	C-3
Extended Function Key Command Summary.....	4-7
Extended Key Functionality.....	4-3
F	
Font Tables.....	C-1
European.....	C-3
Latin1.....	C-2
Standard.....	C-1
Function Key Hex Output Default Values.....	4-1
Function Key Programming.....	4-1
H	
Handshake.....	3-3
Handshake-Out Manipulation Commands.....	4-6
Host Control.....	2-8
I	
Interface Options.....	1-2
Interface Specifications.....	A-1
Internal Communication Devices.....	2-2
K	
Key & Switch Specifications.....	A-1

Key Attribute Commands.....	5-4, 6-4
Key Click.....	3-2, 5-3
Keypad.....	1-2, 2-1
Keypad Hex Output Values.....	D-1
20-Key Keypad.....	D-2
30-Key Keypad.....	D-2
45-Key Keypad.....	D-1
Keypad Operation.....	2-6
KNP Function.....	3-3
L	
Latin1 Display Font Table.....	C-2
LED Control Commands.....	5-6
LED Indicators.....	2-7
Loading Factory Default Settings.....	3-7
Long Bell.....	5-3, 6-4
Long Break.....	4-4
Low Battery Indicator.....	2-1
LT1281.....	2-2
LTC490.....	2-2
M	
Manual Configuration.....	3-1
Modular Interface Connector.....	2-1, 2-2
Modular Interface Connector Signal and Pin Assignments.....	2-2
N	
New Line Mode.....	5-2
Normal Mode.....	5-2
O	
Operating Modes.....	2-7
Operation.....	2-1
Output Control Commands.....	4-4
Overview.....	1-1
P	
Parameter Menu Settings.....	3-1
Parameter Menu Summary.....	3-5
Parameter Modification Commands.....	5-7
Parity.....	3-1
Parity Error.....	3-2
Pause Commands.....	4-4
Pause until Handshake Line Input is +V.....	4-4
Pause until Handshake Line Input is -V.....	4-4
Pause until n Character Received.....	4-5
PCLAT Wired Adapter.....	2-3
Perform Self-Test & Return Results.....	5-5
Physical Specifications.....	A-2
Power.....	2-4
Battery-Powered Units.....	2-4
Line-Powered Units.....	2-4
Power Off.....	5-11
Power Requirements.....	vii
Power Saver Commands.....	5-11

Power Specifications.....	A-1
Power Switch.....	2-1
Private Host Commands.....	6-1
Private Mode	2-8
Private Mode Host Command Summary	6-5
Product Selection Guide.....	vi
Program Custom Character.....	5-11
Program Key.....	5-9
Programming Key Commands	5-9
ProTerms with Optional E-Stops.....	2-2

R

Repeat.....	3-2
Report Key Settings	5-9
Restore Cursor Position	5-2
Restricting Access	3-7
Return Commands.....	6-4
Return Cursor Position.....	5-5
Return Device Attributes	5-5
Return Last Self-Test Results	5-5
Return Terminal Identifier String	5-5, 6-4
RS-232.....	2-2
RS-422.....	2-2

S

Save Cursor Position	5-2
Scroll	3-4
Self-Test.....	3-4
Self-Test & Return Commands.....	5-5
Set and Save Parameters	5-7
Set Blink Attribute	5-4, 6-3
Set Defaults	5-7
Set Parameters.....	5-7
Shift and Ctrl Key Control Commands.....	5-13
Shift Lock	3-4

Shift/Control Key Indicators	3-4
Short Bell.....	5-3, 6-4
Short Break	4-3
Signal and Pin Interface Assignments	2-2
Sound Commands.....	5-3, 6-4
Specifications	A-1
Standard Accessory Cables.....	2-3
Standard Display Font Table	C-1
Stop Bits	3-2
Switch to ANSI Mode	6-4
Switch to Private Mode.....	5-2
Switches and Indicators.....	1-2
Symbols and Conventions.....	1-1

T

Toggle Display Echo	4-4
Toggle Serial Output.....	4-4
Troubleshooting.....	8-1

U

Using ACM in a Robotic Environment Example	5-14
--	------

V

View Angle (Contrast).....	3-4
Viewing Parameter Settings.....	3-6

W

Wait Symbol.....	3-3
------------------	-----

X

XON/XOFF	3-3
----------------	-----