

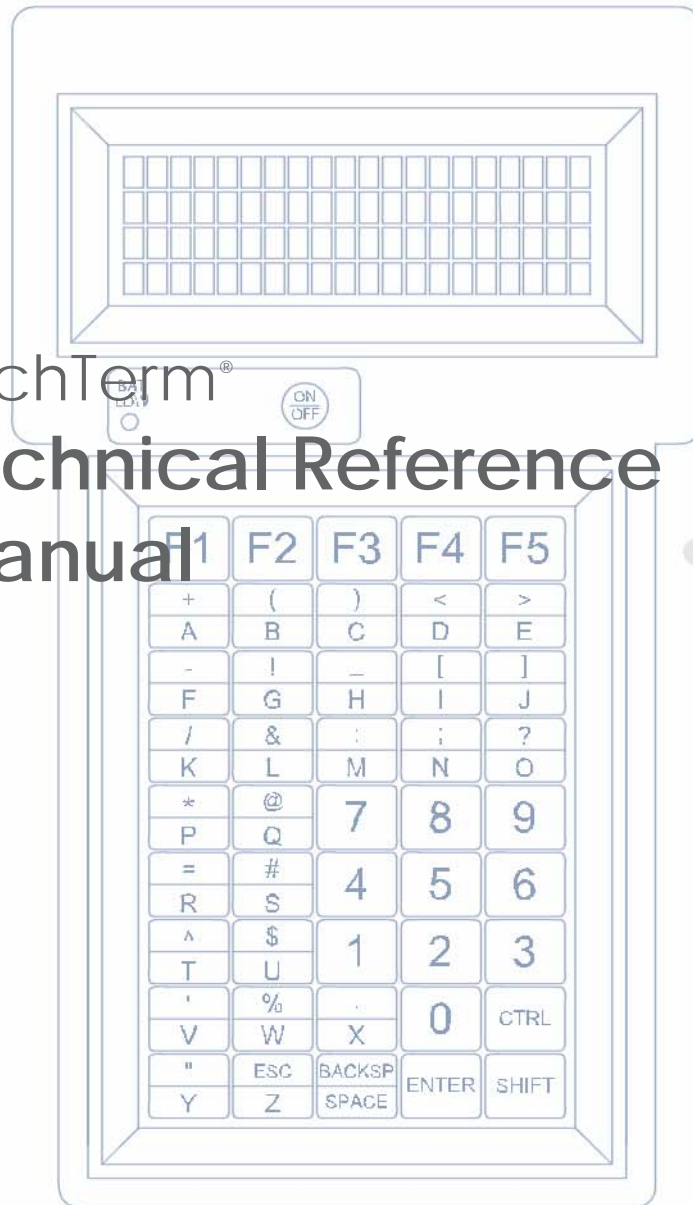

TechTerm[®] Technical Reference Manual



www.2T.com



MAN0010, Rev. E

TechTerm Technical Reference Manual

Document Number: MAN0010, Rev. E

Date of Last Revision: December 16, 2003

Copyright © 1998 – 2003, Two Technologies, Inc.

All rights reserved.

Printed in the United States of America

Copyrights and Trademarks

The 2T logo and TechTerm are registered trademarks of Two Technologies, Inc.

Other products or company names mentioned herein may be the trademarks or registered trademarks of their respective companies.

Reproduction Rights

This manual contains proprietary information. Permission to reproduce or otherwise use portions of the material presented herein is explicitly given to Two Technologies OEMs incorporating the TechTerm into their products. Please note that this publication contains material that may not be appropriate for disclosure to some end users and that Two Technologies assumes no responsibility for technical support burdens incurred, or any other consequences of OEM documentation decisions.

Changes and Addendum

Since Two Technologies is continuously improving the functionality and quality of its products, certain information may not be included in this manual at its time of release. As a result, Two Technologies may provide changed material as separate sheets included with this manual or separately in the form of a change package, as it deems necessary.

Contact Information

Two Technologies, Inc.
419 Sargon Way
Horsham, PA 19044
Phone: 215 441-5305
Fax: 215 441-0423
Web: www.2T.com

To contact Two Technologies by e-mail:

- Sales: sales@2t.com
- Customer Service: customersupport@2t.com
- Technical Support: techsupport@2t.com

Warranty Information

Seller warrants that the product specified in this agreement are free of defects in materials and workmanship, and shall conform to the latest specifications published prior to Buyer's acceptance of the agreement for a period of three years.

Product specifications as defined supersede previous specifications and are complete. Any parameter that is not specifically defined in the specifications is expressly excluded from the warranty. This warranty does not apply to any product which have been subject to misuse, accident, alteration, or if the unit has been serviced by anyone other than an authorized representative of Seller.

Seller's sole obligation to Buyer for products failing to meet specifications shall be, at Seller's discretion, to repair or replace the non-conforming device.

After receiving a Return Authorization (RA) number and a mailing address from Seller, a defective unit covered under this warranty may be returned freight prepaid. Any replacement or repaired product shall carry only the unexpired term of the warranty plus any the period required for repair.

If Buyer has been expressly designated as an Original Equipment Manufacturer (OEM) by Seller, the warranty period shall commence upon the earlier date of (i) delivery to Buyer's first customer, or (ii) 180 days from the original date of shipment by Seller. In the events that products for which: (a) Buyer has title and, (b) have never been used, and (c) have been in the Buyer's possession for more than 180 days and, (d) have an unaltered date code attached, may for an established fixed fee which will not exceed ten percent (10%) of the original purchase price, have the date code updated by the Seller and thereby reestablish those products with a new warranty.

THE FOREGOING WARRANTY AND REMEDIES ARE EXCLUSIVE AND ARE MADE EXPRESSLY IN LIEU OF ALL OTHER WARRANTIES EXPRESSED OR IMPLIED, EITHER IN FACT OR BY OPERATION OF LAW, STATUTORY OR OTHERWISE, INCLUDING WARRANTIES OR MERCHANTABILITY AND FITNESS FOR USE. TWO TECHNOLOGIES NEITHER ASSUMES NOR AUTHORIZES ANY OTHER PERSON TO ASSUME FOR IT ANY OTHER LIABILITY IN CONNECTION WITH THE SALE, INSTALLATION OR USE OF ITS PRODUCTS AND TWO TECHNOLOGIES MAKES NO WARRANTY WHATSOEVER FOR PRODUCTS NOT MANUFACTURED BY TWO TECHNOLOGIES.

TWO TECHNOLOGIES SHALL NOT BE LIABLE FOR DAMAGES DUE TO DELAYS IN DELIVERIES OR USE AND SHALL IN NO EVENT BE LIABLE FOR INCIDENTAL OR CONSEQUENTIAL DAMAGES OF ANY KIND, WHETHER ARISING FROM CONTRACT, TORT OR NEGLIGENCE, INCLUDING, BUT NOT LIMITED TO, LOSS OF PROFITS, LOSS OF GOODWILL, OVERHEAD OR OTHER LIKE DAMAGES.

To maintain your warranty and to avoid creating hazards, only qualified personnel should perform authorized modifications to Two Technologies' products. Two Technologies cannot assume responsibility for any condition affecting the proper operation of this equipment that may result from unauthorized modifications.

Product Returns

If, after inspection, you note any product damage or discrepancies, please contact us promptly within five days of receipt. If the exterior of the package shows obvious signs of damage, please contact your carrier directly.

All items returned to Two Technologies require a Return Material Authorization number (RMA). Please contact Two Technologies' Service department to request an RMA number.

Regulatory Notices

FCC Compliance

This equipment has been tested and found to comply with the limits for Class A digital device, pursuant to Part 15 of the FCC Rules. These limits are designed to provide reasonable protection against harmful interference when the equipment is operated in a commercial environment. This equipment generates, uses, and can radiate radio frequency energy and, if not installed in accordance with the instruction manual, may cause harmful interference to radio communications. Operation of this equipment in a residential area is likely to cause harmful interference, in which case the user will be required to correct the interference at his or her own expense.

Canadian Compliance

This digital apparatus does not exceed the Class A limits for radio noise emissions from digital apparatus set out in the Radio Interference Regulations of the Canadian Department of Communications

Le present appareil numerique n'emet pas de bruits radioelectrique depassant les limites applicables aux appareils numeriques de la class A prescrites dans le Reglement sur le brouillage radioelectrique edicte par le ministere des Communications du Canada.

Certifications

CENELEC



EMI Standards

- EN55022: 1998 (CISPR22, Class A) Information Technology

EMC Standards

- EN50082-1: 1997, General Immunity Part 1

Safety Standard

- EN60950: 2000 Safety of Information Technology Equipment

Warnings

Changes or modifications to this unit, which are not expressly approved by the party responsible for regulatory compliance, could void the user's authority to operate the equipment.

Electrostatic Discharge (ESD)



Electrostatic discharge (static electricity) can have unpredictable adverse effects on any electronic device. Although the design of the TechTerm incorporates extensive ESD-related precautions, ESD can still cause problems. It is good practice to discharge static by touching a grounded metal object before inserting cards or connecting devices.

Product Selection Guide

The TechTerm is an ASCII terminal for use with computers, properly equipped instruments and industrial machinery.

Standard configuration includes a membrane keypad, twisted nematic liquid crystal display and modular interface connection, but other configurations are available. A suffix applied to the model number identifies the configuration as shown below:

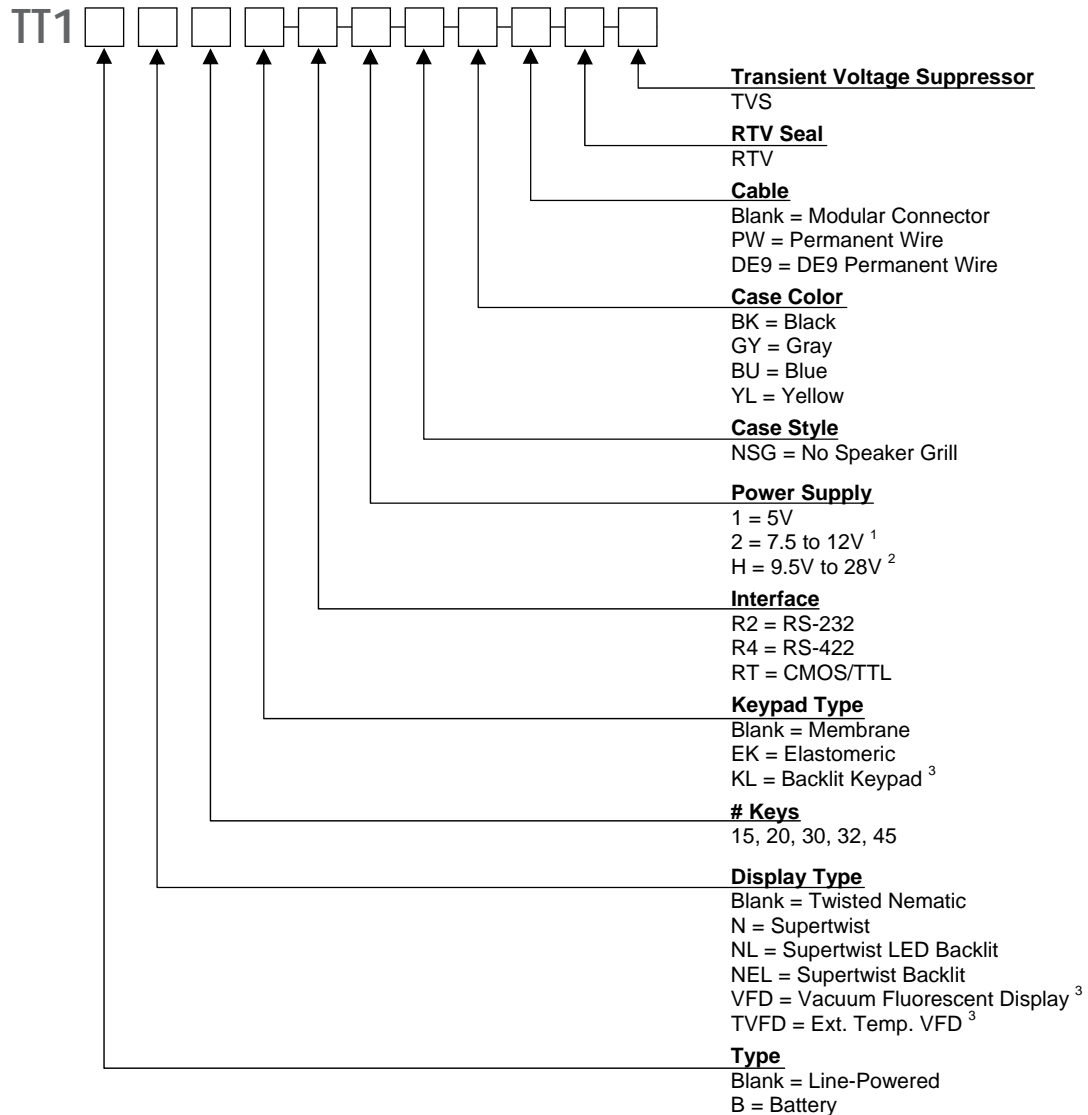

1. A linear regulator (7805A) with a minimum input of 7.5 V and a maximum voltage of 28.0 V that dissipates one watt of power thereby limiting maximum permissible input voltage according to current draw of terminal.
2. A switching type voltage regulator with a minimum input of 9.5 V and a maximum voltage of 28.0 V. Since input voltage is not dependent on the terminal's current draw, it is suitable for all options.
3. Not available on battery units

Power Requirements

Power Supply Options

Depending on the current draw requirements, the terminal may require the use of different power supplies. Use the configuration number listed below (see previous page) to determine the correct power supply:

- "-1" – requires connection to a 5-volt \pm 5% regulated power source.
- "-2" – requires connection to a power source between 7.5 and 12 VDC that can source adequate current. However, depending on a unit's total current draw, an input of up to 28 VDC may be applied. See chart on next page.
- "-H" – requires connection to a power source between 9.5 and 28 VDC that can source adequate current. However, input voltage is not dependent on a terminal's current draw and may be used with all terminal options.

Calculating Total Current Draw

The table below summarizes the current draw requirements for the TechTerm in various configurations (measured at its interface connector). Values listed are approximate due to variations in individual components – actual values may vary.

| <i>Current Draw for Basic Configuration</i> | | |
|---|---|-------------|
| <i>Configuration</i> | <i>Description</i> | <i>Draw</i> |
| TT1R2 | Base Unit with RS-232 | 35 mA |
| TT1R4 | Base Unit with RS-422 | 33 mA* |
| <i>Current Draw for Options</i> | | |
| NL | LED Supertwist Backlit | Add 185 mA |
| NEL/TEL | Supertwist Backlit/Extended Temperature Backlit | Add 45 mA |
| VFD/TVFD | Vacuum Fluorescent Display/Extended Temperature VFD | Add 300 mA |
| KL | Backlit Keypad | Add 80 mA |
| <i>Operational Current Requirements</i> | | |
| | Handshake Low | Add 3 mA |
| | Handshake Floating (not connected) | Add 1 mA |

*Worse case measurement, based on 4000 feet of cable, terminated with a 120-Ohm resistor.

To calculate the total current draw for your terminal configuration:

1. Read the model number on the back of your terminal.
2. Using the model number and the table above, add the current draw for each option to that of the base unit.

Example 1 – TT1NEL45R2:

| | |
|-----------------------------------|--------------|
| RS-232 Option | 35 mA |
| <u>Supertwist Backlit Display</u> | <u>45 mA</u> |
| Calculated Total Current | 80 mA |

Example 2 – TT1VFD45R2:

| | |
|-----------------------------------|---------------|
| RS-232 Option | 35 mA |
| <u>Vacuum Fluorescent Display</u> | <u>300 mA</u> |
| Calculated Total Current | 335 mA |

Determining the Maximum Input Voltage Allowed

The maximum input voltage allowed is based on a unit's current draw.

To determine the maximum input voltage allowed based on current:

1. Calculate the maximum current draw using the table on the previous page.
2. On the following chart, locate the Calculated Total Current on the **Calculated Operating Current** axis of the chart, and then move to the top of **Operating Voltage** range.
3. Look at the corresponding **Maximum Input Voltage Allowed** where the intersection occurs to find the maximum useable voltage for your terminal configuration.

Restricted Input Voltage vs. Current Draw

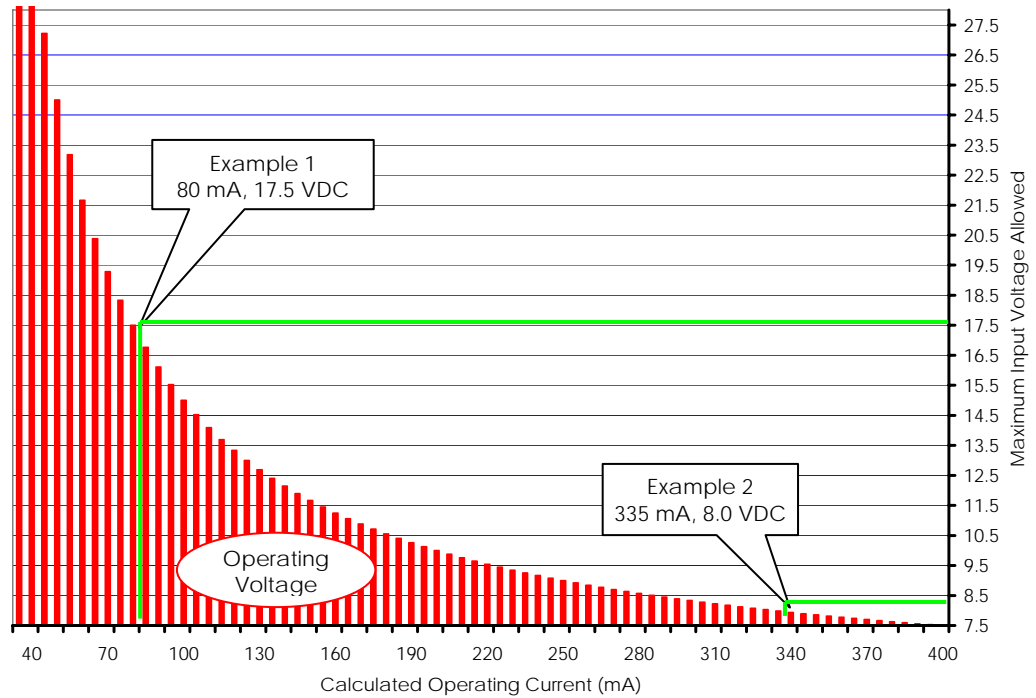

Using Example 1 and the chart above, the 80 mA drawn by the TT1NEL45R2 intersects with 17.5 volts. If the maximum supply voltage to the terminal is greater than 17.5 VDC, it requires a -H power supply configuration.

Using Example 2 and the chart above, the 335 mA drawn by the TT1VFD45R2 intersects with 8.0 volts. If the maximum supply voltage to the terminal is greater than 8.0 VDC, it requires a -H power supply configuration.

To clarify, if your system is supplying 12.0 VDC, the power is acceptable for the TT1NEL45R2 (Example 1), but not for the TT1VFD45R2 (Example 2). Applying 12.0 VDC to the TT1VFD45R2 (Example 2) will **damage** it.

Contents

| | |
|--|------------|
| Chapter 1: Overview | 1-1 |
| About this Manual | 1-1 |
| Symbols and Conventions | 1-1 |
| About Two Technologies | 1-1 |
| About the TechTerm | 1-2 |
| TechTerm Features | 1-2 |
| Chapter 2: Operation | 2-1 |
| Controls and Indicators | 2-1 |
| Cable and Power Connections | 2-2 |
| Internal Communication Devices | 2-2 |
| Signal and Pin Assignments | 2-2 |
| Connecting the Terminal | 2-3 |
| Power | 2-4 |
| Line-Powered Units | 2-4 |
| Battery-Powered Units | 2-4 |
| Keypad Operation | 2-6 |
| Display Operation | 2-6 |
| Cursor Position | 2-6 |
| Operating Modes | 2-7 |
| Host Control | 2-7 |
| Chapter 3: Manual Configuration | 3-1 |
| Introduction | 3-1 |
| Parameter Menu Settings | 3-1 |
| Baud Rate | 3-1 |
| Data Bits | 3-1 |
| Parity | 3-1 |
| Display PE | 3-1 |
| Repeat | 3-2 |
| Echo | 3-2 |
| Handshake | 3-2 |
| Self-Test | 3-2 |
| Power Saver | 3-2 |
| Parameter Menu Summary | 3-2 |
| Changing Parameter Settings | 3-3 |
| Loading Factory Default Settings | 3-3 |
| Restricting Access | 3-4 |
| Chapter 4: Key Programming | 4-1 |
| Introduction | 4-1 |
| Defining Function Keys | 4-2 |
| Chapter 5: Host Commands | 5-1 |
| Introduction | 5-1 |
| Escape Commands | 5-1 |
| Cursor Up | 5-1 |
| Cursor Down | 5-1 |
| Cursor Right | 5-1 |
| Cursor Left | 5-1 |
| Cursor Home & Clear Display | 5-2 |
| Enable Underscore Cursor | 5-2 |
| Disable Underscore Cursor | 5-2 |
| Cursor Home | 5-2 |
| Erase Display | 5-2 |
| Erase Cursor to End of Display | 5-2 |
| Erase Cursor to End of Line | 5-2 |

| | |
|--|------------|
| Long Bell..... | 5-2 |
| Erase Entire Line..... | 5-2 |
| Click | 5-2 |
| Alert | 5-2 |
| Enable Blinking Cursor..... | 5-2 |
| Disable Blinking Cursor | 5-2 |
| Short Bell | 5-2 |
| Enable Key Click..... | 5-3 |
| Disable Key Click | 5-3 |
| Cursor Position | 5-3 |
| Return Terminal Identifier String..... | 5-3 |
| Escape Command Summary..... | 5-4 |
| Control Code Commands | 5-4 |
| Chapter 6: Troubleshooting | 6-1 |
| Appendix A: Specifications | A-1 |
| Appendix B: ASCII Character Set | B-1 |
| Introduction..... | B-1 |
| Appendix C: Keypad Hex Output Values..... | C-1 |
| 45-Key Keypad Hex Output | C-1 |
| 30-Key Keypad Hex Output | C-2 |
| 20-Key Keypad Hex Output | C-2 |
| Index | I-1 |

List of Figures

| | |
|---|-----|
| Figure 2-1: TechTerm Controls and Indicators..... | 2-1 |
| Figure 2-2: Modular Interface Connector..... | 2-2 |
| Figure 2-3: 1210 Series Modular Cable | 2-3 |
| Figure 2-4: PCAT Modular Connector | 2-3 |
| Figure 2-5: Cable Connections..... | 2-4 |
| Figure 2-6: Battery Orientation..... | 2-5 |
| Figure 2-7: Standard Keypads | 2-6 |
| Figure 3-1: Parity Error Symbol..... | 3-1 |
| Figure A-1: TechTerm Case Dimensions..... | A-2 |

List of Tables

| | |
|--|-----|
| Table 2-1: TechTerm Controls and Indicators | 2-1 |
| Table 2-2: Interface Devices | 2-2 |
| Table 2-3: Modular Interface Connector Signal and Pin Assignments..... | 2-2 |
| Table 3-1: Parameter Menu Summary | 3-2 |
| Table 4-1: Function Key Values | 4-1 |
| Table 5-1: Host Command Summary | 5-4 |
| Table 5-2: Control Codes | 5-4 |
| Table B-1: ASCII Character Set and Conversion Codes | B-1 |
| Table C-1: 45-Key Keypad Hex Output Values..... | C-1 |
| Table C-2: 30-Key Keypad Hex Output Values..... | C-2 |
| Table C-3: 20-Key Keypad Hex Output Values..... | C-2 |



Chapter 1: Overview

About this Manual

Intended for authorized developers with prior knowledge of hand held PC application development, this manual describes the advanced features, operations and interface capabilities of Two Technologies' TechTerm terminals. It is not for use by end-users.

Unless otherwise stated, the operational characteristics described herein correspond to factory default configurations and settings as shipped from Two Technologies with a standard 45-key keypad.

Because TechTerm terminals are highly customizable products with several optional configurations and special keypad layouts, this manual only describes standard features and operation. For custom configurations and special options, consult the appropriate supplemental manual or addendum.

It is beyond the scope of this manual to provide operating system tutorials or information about commercial or customized TechTerm application programs and connected equipment. This information should be available in the manuals that accompany those products.

Wherever used herein, the term "TechTerm" applies to all models (except as noted).

NOTICE

The information contained in this manual applies only to TechTerm terminals manufactured after May 2001 (Serial Number HH184408 and above).

Because newer models contain additional functions not found on previous models, use of these functions on older terminal may cause unexpected results.

Symbols and Conventions

Unless otherwise noted, this manual uses the following format conventions to distinguish elements of text:

- New terms used in this manual initially appear in *Italics*, for example: *host*.
- Names of keys as shown on a keypad appear in **bold type**, for example: **CTRL**.
- Names of parameter values appear in **uppercase letters**, for example: **ENABLE**.
- Esc represents the ASCII escape character in **Escape commands**, for example: **Esc [4n**.
- A lowercase "h" appearing after a number denotes a **hexadecimal value**, for example: **1Bh**.

About Two Technologies

Two Technologies has been producing rugged hand held and panel mount terminals and computers for over fifteen years. By implementing state of the art design and manufacturing techniques, we revolutionized hand held terminals and computers inside and out. Today, Two Technologies offers over a dozen cost-effective solutions serving virtually every market.

About the TechTerm

Specifically designed for industrial applications, the TechTerm is a rugged and fully functional ASCII terminal with selectable operating parameters and fifteen menu-programmable function keys. Parameters and function key definitions are stored in non-volatile memory.

Commands issued by the host device can directly control the TechTerm's cursor movement, cursor style and signal tones from the built-in speaker.

TechTerm Features

Two Technologies offers the TechTerm with the following features. You can find additional information regarding specifications in [Appendix A](#).

Power

The TechTerm is available as a line-powered or battery-powered unit. Line-powered units use a 7.5-12 VDC linear regulator. A 5 VDC ($\pm 5\%$) transformer and optional 9.5-28 VDC switching regulator are also available, depending on current draw.

Battery-powered TechTerms come equipped with a push-button power switch, low-battery indicator and a rechargeable Nickel Metal Hydride (NiMH) battery. Operating time on a full charge is up to 40 hours, depending on use. Battery-powered TechTerms can also operate on six AA alkaline batteries

Display

TechTerms come with a standard 80-character monochrome liquid crystal display that features the standard U. S. ASCII character set as dark characters on a light background.

A supertwist nematic display is available for applications that require a greater viewing angle. For applications where ambient light is insufficient, backlit supertwist and LED Backlight supertwist displays are available for line-powered units. Other display options for line-powered units include a Vacuum Fluorescent Display (VFD) and an extended temperature VFD.

Keypad

Securely framed and clamped into place, the keypad surface provides excellent splash resistance and prevents curling or peeling of the keypad overlay. Keypad layouts include 45, 30, and 20 keys available with standard or custom graphics and 32 and 15 keys available with custom graphics. Keypads can be made from your choice of elastomeric or membrane material.

Switches and Indicators

You can program up to fifteen function keys (keyboard dependent) with single characters and save in non-volatile memory.

Battery-powered TechTerms have an On/Off switch and a low battery indicator.

Interface Options

Interface options for the TechTerm include RS-232, RS-422 or CMOS/TTL protocols. Communication (up to 9600 bps) with a host device is through a modular 6-pin connector.

Durability

Like all Two Technologies' products, the TechTerm is remarkably rugged. The case consists of Cyclocac ABS, one of the most durable, chemical-resistant materials available on the market today.



Chapter 2: Operation

Controls and Indicators

Figure 2-1 describes the possible components and indicators found on the front of a TechTerm as shown in Table 2-1.

Figure 2-1: TechTerm Controls and Indicators

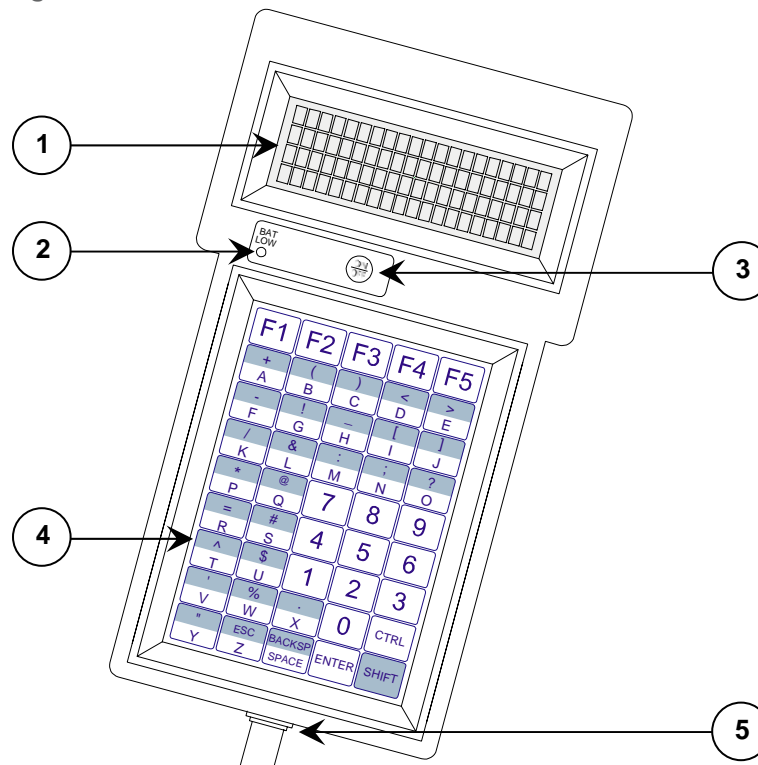

Table 2-1: TechTerm Controls and Indicators

| <i>Item</i> | <i>Control/Feature</i> | <i>Description</i> |
|-------------|-----------------------------|---------------------------------------|
| 1 | Display | 4 Rows of 20 (5 x 7 pixel) characters |
| 2 | Low Battery Indicator | Battery-powered unit only |
| 3 | Power Switch | Battery-powered unit only |
| 4 | Keypad | 45-key keypad (standard) |
| 5 | Modular Interface Connector | Supplies communication and power |

Cable and Power Connections

Internal Communication Devices

The following table lists the internal interface devices used in the TechTerm.

Table 2-2: Interface Devices

| <i>Interface</i> | <i>Manufacturer</i> | <i>Device</i> |
|------------------|---------------------|---------------|
| RS-232 | Linear Technology | LT1281 |
| RS-422 | Linear Technology | LTC490 |

Signal and Pin Assignments

Modular Interface Connector

Figure 2-2 depicts the standard six-pin modular interface connector found on the TechTerm. Table 2-3 describes its signal and pin assignments.

Warning: Use the six-pin modular receptacle for compatible serial devices only. Despite its physical similarity to modular telephone connectors, it is not compatible with telephone lines or signals. Connecting the terminal to a telephone line will damage it and void the warranty.

Figure 2-2: Modular Interface Connector

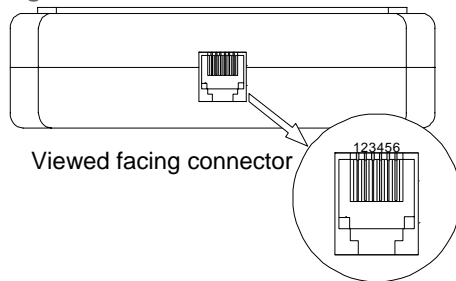

Table 2-3: Modular Interface Connector Signal and Pin Assignments

| <i>Pin</i> | <i>RS-232/CMOS/TTL</i> | <i>RS-422</i> |
|------------|-----------------------------|--------------------------|
| 1 | + Supply to terminal | + Supply to terminal |
| 2 | Handshake-In to terminal | + Data-In to terminal |
| 3 | Handshake-Out from terminal | + Data-Out from terminal |
| 4 | Data-In to terminal | - Data-In to terminal |
| 5 | Data-Out from terminal | - Data-Out from terminal |
| 6 | Common | Common |

Standard Accessory Cables

Standard modular cables (1210-7 and 1210-15) that mate with the terminal's modular interface connector and Two Technologies' PCAT wired adapter are available as optional accessories. These cables will reverse the signal output from the terminal (see illustration below). Non-reversing modular cables (1210-7-NR and 1210-15-NR) are also available.

Figure 2-3: 1210 Series Modular Cable

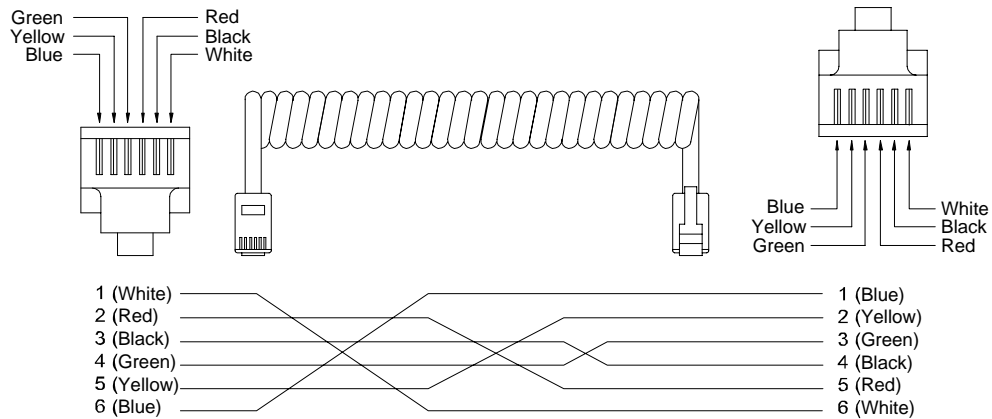

PCAT Wired Adapter

The PCAT modular connector enables connection to a host device as well as supplying a connection for a power supply.

Figure 2-4: PCAT Modular Connector

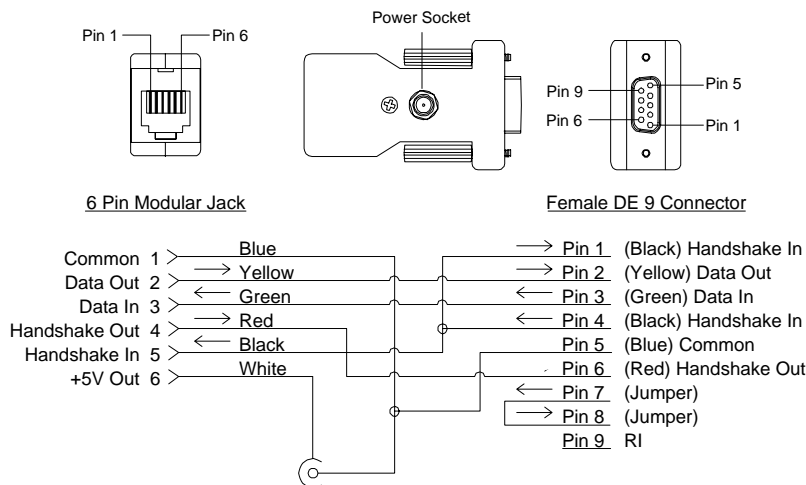

Note: Pin descriptions assume connection through a Two Technologies' 1210 series modular cable to the terminal's modular connector.

Connecting the Terminal

To connect the terminal to a host device using Two Technologies parts:

1. Plug one end of a [1210 modular cable](#) into the modular connector on the bottom of the terminal. Plug the other end into the [PCAT adaptor](#).
2. Plug the PCAT adaptor into the host device.

Line-Powered Units

To supply power to a line-powered TechTerm:

1. Plug one end of a [1210 modular cable](#) into the modular connector on the bottom of the terminal. Plug the other end into the [PCAT adaptor](#).

Figure 2-5: Cable Connections

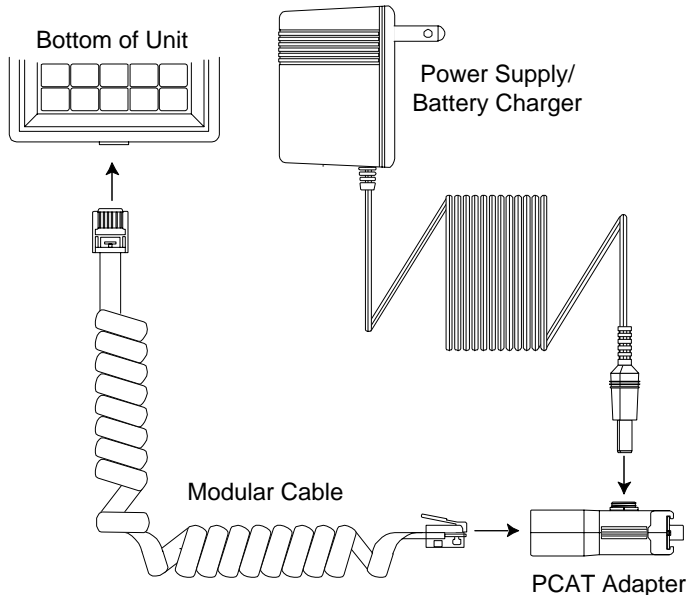

2. Using a Two Technologies' power supply (such as a Two Technologies 1226-1 linear power supply for units with a -2 power supply configuration), plug the power supply connector into the PCAT adaptor and then plug the power supply into a 120 VAC 60 Hz power outlet.
3. The terminal should turn on and a blinking cursor should appear on the display. If the terminal does not turn on, refer to the [Troubleshooting](#) section of this manual for help.

Battery-Powered Units

Battery-powered TechTerms come equipped with a rechargeable Nickel Metal Hydride (NiMH) battery that has exceptional charge life without the "charge memory" characteristic of conventional nickel cadmium batteries. Partially discharged batteries or extended periods with the charger left connected will not adversely affect battery life or performance.

Operating time on a full charge is up to 40 hours, depending on use. The time required for a full charge depends on the initial state of the battery. With the terminal off, this time should not exceed eight hours. Battery-powered TechTerms can also operate on six AA alkaline batteries.

Battery-powered TechTerms also have a low battery indicator, which indicates that there is approximately one hour of operating power remaining. A built-in power saver will turn off battery-powered TechTerms after ten minutes of inactivity. Any key press or character received by the TechTerm will reset the power-saver timer.

To turn on battery-powered units, press the On/Off switch. The terminal should turn on and a blinking cursor should appear on the display. If the terminal does not turn on, refer to the [Troubleshooting](#) section of this manual for help.

Charging the Unit

Because the internal battery charger senses several conditions, including temperature, you should charge the unit away from any known or potential heat sources. Units exposed to temperatures in excess of 90 degrees Fahrenheit during the charge cycle may experience incomplete charging and reduced operating time per charge.

To recharge the Nickel Metal Hydride (NiMH) battery pack, plug the Two Technologies' power supply/battery charger (Part # 13799) into the PCAT adapter and then plug the power supply/battery charger into a 120 VAC 60 Hz power outlet.

Changing Batteries

To change batteries:

1. With the unit face down, pull the battery cover retaining clip up from its recessed slot and turn the clip in a counter clockwise motion.
2. Lift the cover up and remove the batteries. If the unit contains a battery pack, use the tab on the battery pack to lift up and then out.
3. Insert the new batteries or battery pack into the unit using the orientation shown in the figure below.

Figure 2-6: Battery Orientation

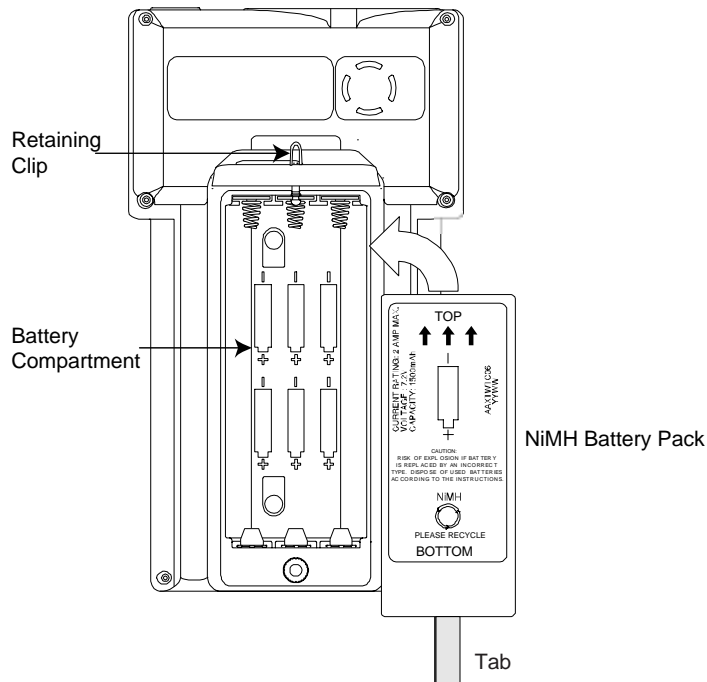

4. Close the battery cover and turn the battery cover retaining clip clockwise to lock the cover.

Keypad Operation

The standard 30 position and 45 position keypads consist of uppercase letters, digits 0 through 9, punctuation marks, symbols, function keys and keys for Escape (**ESC**), Space (**SPACE**), Backspace (**BACKSP/BKSP**), Control (**CTRL**), Shift (**SHIFT**) and Enter (**ENTER**). You can program the **SHIFT** key to operate in normal or locked mode. In the locked mode, pressing a modifier key will toggle its respective state.

Transmission of control characters will cancel the control state. If both the Shift and Control states are active, lowercase alphabetic characters will replace corresponding uppercase alphabetic characters. All keys, with the exception of **CTRL** and **SHIFT**, may be re-assigned with user-programmed characters or character strings from the key output definition menu.

The standard 20 position keypads consist of the digits 0 through 9, functions keys and keys for Yes (**YES**), No (**NO**), Backspace (**BKSP**), Space (**SPACE**) and Enter (**ENTER**).

Figure 2-7: Standard Keypads

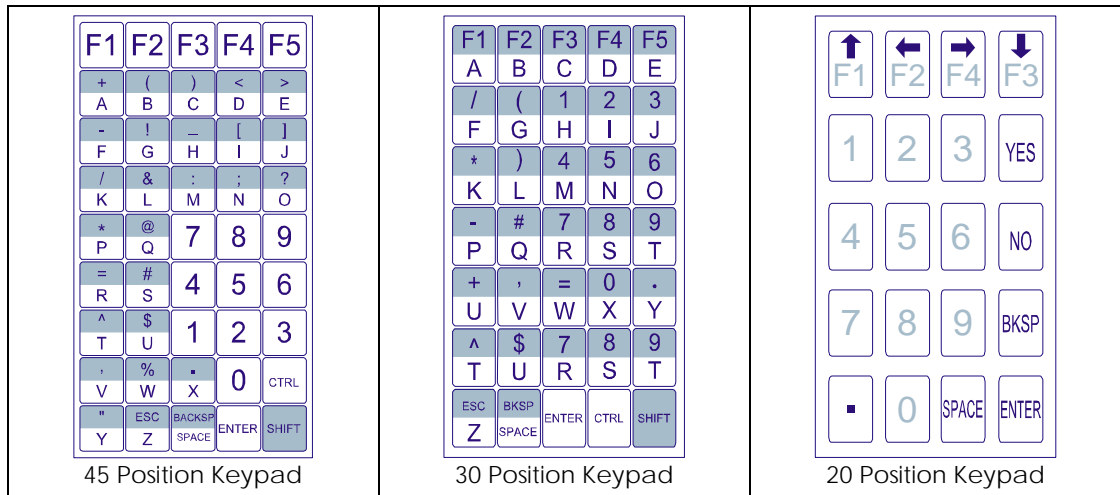

Display Operation

The TechTerm screen displays the standard U.S. ASCII 96 character set. Characters appear at the display at the current cursor location.

Cursor Position

Typically, the cursor moves from left to right as the terminal displays characters (unless altered by Escape commands). The cursor is host command programmable as a block or underscore, blinking or non-blinking.

Whenever a character appears in the last position of the top three rows, the cursor will move to the leftmost position on the next row. Whenever a character appears in the last position on the bottom row, the terminal will temporarily hide the cursor. After scrolling the screen up one row, the TechTerm will display the next character in the first position on a new bottom row followed by the cursor.

Operating Modes

TechTerms have several operating modes. The default mode is Terminal mode. It allows the terminal to display characters, respond to commands sent by a connecting device, and send characters to the connecting device as keys are pressed. Other modes, described later in this manual, enable you to [set operating parameters](#) and [program function key definitions](#).

Host Control

The design of TechTerms allows a connecting device (or “*host*”) to control its functions through the transmission of a string of special characters.

Referred to as “*Escape commands*” (because each character string begins with the ASCII escape character), these character strings enable the host to move the cursor, sound an alert, program the function keys and set any of the operating parameters.



Chapter 3: Manual Configuration

Introduction

A comprehensive set of user-settable operating parameters and programmable function keys makes the TechTerm suitable for diverse applications. Each settable parameter and programmable function key has a default value. These values are stored in the terminal's permanent memory.

This chapter describes each operating parameter in detail, as well as how to set the parameters and load the default values. Chapter 4 covers programmable function keys.

Parameter Menu Settings

The following section describes the parameters that you can program in a TechTerm. A summary ([Table 3-1](#)) appears at the end of the section.

Baud Rate

This parameter sets the number of bits per second transmitted. The data rate can be set to: 300, 600, 1200, 2400, 4800 or 9600 baud. The default value is 9600.

Data Bits

This parameter sets the number of data bits transmitted per character, either seven (7) or eight (8). The default value is eight (8).

Parity

This parameter enables/disables the host's ability to perform error checking on incoming characters and ensure accuracy. Allowable settings are EVEN, ODD, MARK, SPACE and IGNORE. The default value is EVEN.

When set to EVEN, ODD, MARK or SPACE, the terminal will perform the corresponding check on incoming data. When set to IGNORE will still add a parity check bit to each character, but the value of that bit is indeterminate.

Note: Should the host require a communication setting of 8 data bits with no parity, select 7 data bits and SPACE parity.

Display PE

When using a parity of EVEN, ODD, MARK or SPACE, you can enable this parameter to display a special character ([Figure 3-1](#)) when a parity error occurs. With this option disabled, the character displays as received. The default value is ENABLED.

Figure 3-1: Parity Error Symbol



Repeat

This parameter determines the repeat keypad character rate while the key remains pressed. The allowable values are SLOW (10 characters per second), FAST (18 characters per second) and DISABLED. The default value is FAST. When set to DISABLED, key repeat is inoperative. In all cases, there is a short delay between the initial character and the start of the repeat.

Echo

This parameter enables/disables the TechTerm's ability to display (echo) keypad entries on the screen. When set to DISABLED (the default value), only characters received by the terminal will display.

Handshake

This parameter enables/disables use of the two handshake lines (DTR-DSR or RTS-CTS) in models equipped with a RS-232 or TTL/CMOS interface. The Handshake parameter has a default value of ENABLED.

When enabled, the terminal will only send characters to the host when it detects the Handshake-In line. If the terminal cannot process the incoming characters, it will drop its Handshake-Out line to the host. Any characters sent in this state will be lost.

When disabled, the terminal will assert the Handshake-Out line and ignore the Handshake-In line.

Self-Test

This setting determines if the TechTerm will perform a confidence test at boot-up. The test displays the U.S. ASCII Character Set and checks the internal RAM and ROM. The TechTerm will beep when the test is completed. If an error occurs, the TechTerm will display an error message. The Self-Test parameter has a default value of DISABLED.

Power Saver

The Power Saver parameter is available on battery-powered units only. When enabled, the terminal will turn itself off after ten minutes of inactivity (no key press or characters receive from host). The Power Saver parameter has a default value of ENABLED

Parameter Menu Summary

The following table lists the allowable settings and default values available through the Parameter menu.

Table 3-1: Parameter Menu Summary

| <i>Parameter</i> | <i>Options (Default In Bold)</i> |
|--------------------------|---|
| BAUD | 300, 600, 1200, 2400, 4800, 9600 |
| DATA BITS | 7 , 8 |
| PARITY | EVEN , ODD, MARK, SPACE, IGNORE |
| DISPLAY PE | ENABLED , DISABLED |
| REPEAT | SLOW, FAST , DISABLED |
| ECHO | ENABLED, DISABLED |
| HANDSHAKE | ENABLED , DISABLED |
| SELF TEST | ENABLED, DISABLED |
| POWER SAVER ¹ | ENABLED , DISABLED |

1. Only appears on battery-powered units.

Changing Parameter Settings

The following procedure describes how to change parameter settings using a 45 or 30-key TechTerm, other keypad configurations may work differently.

To change the parameters settings:

1. For 45 or 30-key terminals, simultaneously hold **CTRL** and **SHIFT**, and press **F1**.
For 20-key terminals, simultaneously hold **BKSP** and **ENTER**, and press **F1**.

Note: You can also access the Parameter menu, by removing power, simultaneously holding **CTRL**, **SHIFT** and **F3** (for 20-key terminals, use **BKSP**, **ENTER** and **F3**), and reapplying power.

The Parameter menu appears with the first parameter on the top line.

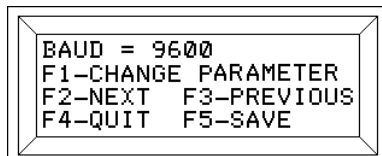

2. To change the value of the current parameter, press **F1**.
3. To view the next parameter, press **F2**.
4. To view the previous parameter, press **F3**.
5. To save any changes and exit the menu on 45 or 30-key terminals, press **F5**. To exit the menu without saving any changes, press **F4**.

To save any changes and exit the menu on 20-key terminals, press **F4**.

If you make any changes, the TechTerm will display the following screen:

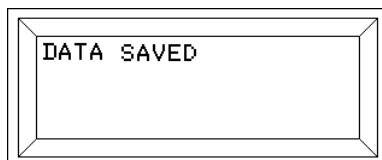

Loading Factory Default Settings

The following procedure describes how to load the factory default settings using a 45 or 30-key TechTerm, other keypad configurations may work differently.

To load the factory default settings:

1. Remove power or turn off the TechTerm.
2. For 45 or 30-key terminals, simultaneously hold **CTRL**, **SHIFT** and **F1**, and reapply power.
For 20-key terminals, simultaneously hold **BKSP**, **ENTER** and **F1**, and reapply power.
3. After the terminal sounds an alert and displays the "LOAD DEFAULTS?" message, release the keys.

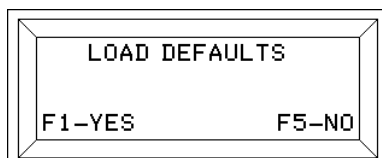

4. For 45 or 30-key terminals, press **F1** to reload the default values. Press **F5** to leave the parameters unchanged.

For 20-key terminals, press **F1** to reload the default values. Press **F4** to leave the parameters unchanged.

Restricting Access

The following procedure describes how to prevent access to the Parameter menu and disable function key programming using a 45 or 30-key TechTerm, other keypad configurations may work differently.

To restrict access to the Parameter menu and disable function key programming:

1. Remove power or turn off the TechTerm.
2. For 45 or 30-key terminals, simultaneously hold **CTRL**, **SHIFT** and **F5**, and reapply power.
For 20-key terminals, simultaneously hold **BKSP**, **ENTER** and **F5**, and reapply power.

In either case, the terminal will display the following message:

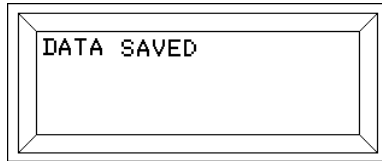

To re-enable access to the Parameter menu and function key programming, simply repeat the procedure above.



Chapter 4: Key Programming

Introduction

You can program between 10 and 15 function keys with single ASCII characters, including non-printing characters depending on the keypad type (Figure 2-7). All programmable function key settings are stored in the TechTerm's nonvolatile memory.

Notes: To display the results of key programming on your terminal, you must enable ECHO. The number of programmable function keys may vary with custom keypad configurations.

Table 4-1: Function Key Values

| <i>Keypad</i> | <i>Key</i> | <i>Value</i> | <i>+ SHIFT</i> | <i>+ CTRL</i> |
|---------------|------------|--------------|----------------|---------------|
| 45 Key | F1 | 11h | 61h | 66h |
| | F2 | 12h | 62h | 67h |
| | F3 | 13h | 63h | 68h |
| | F4 | 14h | 64h | 69h |
| | F5 | 15h | 65h | 6Ah |
| 30 Key | F1 | 41h | 11h | 01h |
| | F2 | 42h | 12h | 02h |
| | F3 | 43h | 13h | 03h |
| | F4 | 44h | 14h | 04h |
| | F5 | 45h | 15h | 05h |
| 20 Key | F1 | 41h | N/A | N/A |
| | F2 | 42h | N/A | N/A |
| | F3 | 43h | N/A | N/A |
| | F4 | 44h | N/A | N/A |

Defining Function Keys

The following procedure describes how to define a function key using a 45 or 30-key TechTerm, other keypad configurations may work differently.

To define a function key:

1. On 30-key and 45-key terminals, simultaneously hold **CTRL**, **SHIFT** and **F2**.

On 20-key terminals, simultaneously hold **BKSP**, **ENTER** and **F2**. The screen will display:

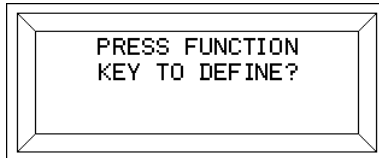

2. Select a key to program, by pressing that key (for example, F1). The screen will then show hex code for that key (H11).

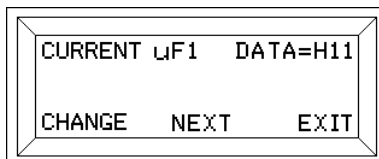

3. Press **F1** to change the current value. You can also press **F3** to return to the previous screen or press **F5** to exit (on 20-key terminals, press **F4**). When changing the current value, the screen will display:



4. Enter the new hex code. If needed, press **F3** to change your entry.
5. To save you changes, press **F5** (on 20-key terminals, press **F4**). To quit without saving, press **F1**. When saving your changes, the screen will display:

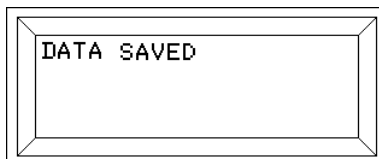

Warning! Do **not** remove power from the terminal while the above message appears on the screen or you will corrupt **all** stored data. Should you remove power during this time, you will have [load default values](#).

Notes: You can disable function key programming by simultaneously pressing **CTRL**, **SHIFT** and **F5**. Refer to the [Restricting Access](#) procedure for additional information.

To display the results of key programming on your terminal, you must enable ECHO.



Chapter 5: Host Commands

Introduction

The TechTerm will respond to certain command strings issue from a host device to control some of its functionality. These commands can start with either an Escape character or a Control character.

For example, sending an Esc E will clear the display and move the cursor to the home position), while sending a Ctrl K will move the cursor down one row.

Note: Do not use spaces between characters in Control or Escape commands. Any spacing shown for Escape commands in this chapter is for clarity only unless otherwise noted.

Escape Commands

This section describes the Escape commands that a host devices can issue to control the TechTerm's functionality. A summary of Escape commands appears at the end of this section.

Note: You cannot buffer sound commands. To produce properly spaced chain sounds, the host must delay a short time between issuing sound commands.

Cursor Up

Syntax Esc A

Notes Moves the cursor up one row, but not beyond the start or end of a line, nor will it scroll the display

Cursor Down

Syntax Esc B

Notes Moves the cursor down one row, but not beyond the start or end of a line, nor will it scroll the display

Cursor Right

Syntax Esc C

Notes Moves the cursor one position to the right, but not beyond the start or end of a line, nor will it scroll the display

Cursor Left

Syntax Esc D

Notes Move the cursor one position to the left, but not move the start or end of a line, nor will it scroll the display

Cursor Home & Clear Display

Syntax Esc E

Notes Includes the character at the cursor location

Enable Underscore Cursor

Syntax Esc F

Disable Underscore Cursor

Syntax Esc G

Cursor Home

Syntax Esc H

Erase Display

Syntax Esc I

Notes Includes the character at the cursor location, but does not alter the cursor position

Erase Cursor to End of Display

Syntax Esc J

Notes Includes the character at the cursor location and does not alter the cursor position

Erase Cursor to End of Line

Syntax Esc K

Notes Includes the character at the cursor location and does not alter the cursor position

Long Bell

Syntax Esc L

Erase Entire Line

Syntax Esc M

Notes Includes the character at the cursor location and does not alter the cursor position

Click

Syntax Esc P

Alert

Syntax Esc Q

Enable Blinking Cursor

Syntax Esc R

Disable Blinking Cursor

Syntax Esc S

Short Bell

Syntax Esc T

Enable Key Click

Syntax Esc U

Disable Key Click

Syntax Esc V

Cursor Position

Syntax Esc Y *Pr Pc*

Notes Moves the cursor to a specified location where *Pr* is the ASCII character equivalent of the row numbers and *Pc* is the ASCII character equivalent of the column numbers shown below.

| <i>Row (Pr)</i> | <i>ASCII</i> | <i>Column (Pc)</i> | <i>ASCII</i> | <i>Column (Pc)</i> | <i>ASCII</i> |
|-----------------|--------------|--------------------|--------------|--------------------|--------------|
| 1 | SP | 1 | SP | 11 | * |
| 2 | ! | 2 | ! | 12 | + |
| 3 | " | 3 | " | 13 | , |
| 4 | # | 4 | # | 14 | - |
| | | 5 | \$ | 15 | . |
| | | 6 | % | 16 | / |
| | | 7 | & | 17 | 0 |
| | | 8 | ' | 18 | 1 |
| | | 9 | (| 19 | 2 |
| | | 10 |) | 20 | 3 |

Examples Esc Y !) will send the cursor to Row 2, Column 10

Esc Y #0 will send the cursor to Row 4, Column 17

Esc Y !+ will send the cursor to Row 2, Column 12

Return Terminal Identifier String

Syntax Esc Z

Notes This command sends the following identifier string to the host:

TT1*BCCCCMN*

Where *B* indicates a battery unit (if applicable), *CCCC* is the four-byte hexadecimal checksum of the terminal's program memory and *NN* is the keypad type (30 = 30-key keypad or blank = 45-key keypad).

When using this command to identify the terminal type, do not include the checksum as it may change.

Escape Command Summary

The following table is a summary of the available host commands.

Table 5-1: Host Command Summary

| <i>Command</i> | <i>Code/Syntax</i> |
|-----------------------------------|--------------------|
| Cursor Up | Esc A |
| Cursor Down | Esc B |
| Cursor Right | Esc C |
| Cursor Left | Esc D |
| Cursor Home & Clear Display | Esc E |
| Enable Underscore Cursor | Esc F |
| Disable Underscore Cursor | Esc G |
| Cursor Home | Esc H |
| Erase Display | Esc I |
| Erase Cursor to End of Display | Esc J |
| Erase Cursor to End of Line | Esc K |
| Long Bell | Esc L |
| Erase Entire Line | Esc M |
| Click | Esc P |
| Alert | Esc Q |
| Enable Blinking Cursor | Esc R |
| Disable Blinking Cursor | Esc S |
| Short Bell | Esc T |
| Enable Key Click | Esc U |
| Disable Key Click | Esc V |
| Cursor Position | Esc Y <i>Pr Pc</i> |
| Return Terminal Identifier String | Esc Z |

Control Code Commands

The host can control some of TechTerm's functionality by sending it commands that start with the Control character. For example, sending a Ctrl G will sound the bell on the TechTerm.

Table 5-2: Control Codes

| <i>Command</i> | <i>Code</i> |
|----------------------------|-------------|
| Send ENQ | Ctrl E |
| Sounds Bell | Ctrl G |
| Back Space Cursor | Ctrl H |
| Line Feed | Ctrl J |
| Cursor Down | Ctrl K |
| Cursor Left to Column 1 | Ctrl M |
| Delete Character at Cursor | DEL |



Chapter 6: Troubleshooting

Cursor does not appear on display

Possible Cause: No power to terminal (host supplied)

Solution: Verify proper voltage to terminal

Possible Cause: No power to terminal (adapter supplied)

Solution: Verify wall plug is functional and wiring of adapter (if wired as kit)

Possible Cause: Reversed polarity, improper wiring or wrong cable type

Solution: Check cable and connector wiring

Possible Cause: Cursor not enabled

Solution: Re-enable the cursor by sending an Esc [4t (ANSI mode) or Esc F (Private mode) or by changing the CURSOR parameter setting

Terminal resets or locks-up

Possible Cause: Low voltage output

Solution: Verify proper voltage to terminal

Possible Cause: Cable resistance too high or wire gauge too small

Solution: Cable should be 26 AWG or larger

Possible Cause: Handshaking between host and terminal

Solution: When using handshaking, verify that the wiring between the host and terminal is correct, that you have the HANDSHAKE parameter enabled and that the handshake line from the host is asserted

When not using handshaking, make sure you have the HANDSHAKE parameter disabled

Terminal does not perform self-test

Possible Cause: Self-test parameter disabled

Solution: Change SELF TEST parameter to ENABLE

Terminal not receiving or displaying correct characters

Possible Cause: Parity settings incorrect

Solution: Change PARITY parameter to correct setting

Possible Cause: Data bits incorrect

Solution: Change DATA BITS parameter to correct setting

Possible Cause: Incorrect BAUD rate

Solution: Change BAUD parameter to correct setting

Possible Cause: Handshaking between host and terminal

Solution: When using handshaking, verify that the wiring between the host and terminal is correct, that you have the HANDSHAKE parameter enabled and that the handshake line from the host is asserted

When not using handshaking, make sure you have the HANDSHAKE parameter disabled

Possible Cause: Reversed polarity, improper wiring or wrong cable type

Solution: Check cable and connector wiring

Terminal displays PE character

Possible Cause: Incorrect parity setting

Solution: Change the PARITY setting on the terminal to match the host or vice versa

Possible Cause: Handshaking between host and terminal

Solution: When using handshaking, verify that the wiring between the host and terminal is correct, that you have the HANDSHAKE parameter enabled and that the handshake line from the host is asserted

When not using handshaking, make sure you have the HANDSHAKE parameter disabled

Terminal generates continuous sound while pressing key

Possible Cause: Handshaking between host and terminal

Solution: When using handshaking, verify that the wiring between the host and terminal is correct, that you have the HANDSHAKE parameter enabled and that the handshake line from the host is asserted

When not using handshaking, make sure you have the HANDSHAKE parameter disabled

Terminal displays double characters

Possible Cause: Echo turned on

Solution: Disable ECHO parameter

Cannot access parameter mode or function key programming

Possible Cause: Menu lock-out enabled

Solution: Remove power, simultaneously hold **CTRL**, **SHIFT** and **F5**, and reapply power

Possible Cause: Handshaking between host and terminal

Solution: When using handshaking, verify that the wiring between the host and terminal is correct, that you have the HANDSHAKE parameter enabled and that the handshake line from the host is asserted

When not using handshaking, make sure you have the HANDSHAKE parameter disabled

Terminal losing characters

Possible Cause: Handshaking between host and terminal

Solution: When using handshaking, verify that the wiring between the host and terminal is correct, that you have the HANDSHAKE parameter enabled and that the handshake line from the host is asserted

When not using handshaking, make sure you have the HANDSHAKE parameter disabled

Function keys not sending correct values

Possible Cause: Key accidentally reprogrammed

Solution: Reprogram function key

Possible Cause: EEPROM corrupted by line disturbance

Solution: Restore factory defaults and then reprogram parameters and function keys

Possible Cause: Terminal reset to factory defaults after repair

Solution: Reprogram function keys



Appendix A: Specifications

| |
|---|
| <p>Display</p> <ul style="list-style-type: none"> ▶ Reflective/Transreflective Liquid Crystal Display ▶ 4 Row x 20 Character Display Format ▶ US ASCII Character Set (5 x 7 pixels) ▶ Dark Characters on Light Background (except VFD) ▶ Options: Supertwist, Supertwist Backlit, LED Supertwist Backlit, VFD* and Extended Temperature VFD* <p><small>* Not available on battery-powered units.</small></p> |
| <p>Keys & Switches</p> <ul style="list-style-type: none"> ▶ Type: Membrane or Elastomeric ▶ Standard Layouts: 45-key (9 rows x 5 columns) and 30-key (6 x 5) ▶ Custom Layouts: 20-key (5 x 4), 32-key (8 x 4) and 15-key (5 x 3) ▶ Feedback: Tactile and Audible ▶ Programmability: Up to five function keys with up to fifteen definitions (depending on keypad) ▶ Optional Backlit Keypad Available |
| <p>Power</p> <ul style="list-style-type: none"> ▶ Line: <ul style="list-style-type: none"> ▪ Voltage: 5 VDC +/- 5%, 7.5-12 VDC* Linear Regulator or 9.5-28 VDC Switching Regulator <small>Maximum voltage depends on current draw.</small> ▪ Current: 15-20 mA Nominal (RS-232, RS-422)* <small>Some options require additional current (for example, a backlight adds 50 mA)</small> ▶ Battery: <ul style="list-style-type: none"> ▪ Nickel Metal Hydride Rechargeable Pack, (up to 40 hours of run time without backlight) ▪ 6 AA Alkaline Batteries (not shipped with unit) |
| <p>CPU</p> <ul style="list-style-type: none"> ▶ Type: Atmel AT89C55WD ▶ Speed: 11.059 MHz |
| <p>Interface</p> <ul style="list-style-type: none"> ▶ Type: RS-232, RS-422 or CMOS/LSTTL level ▶ Handshaking: 2 Lines (DTR, DTS) for RS-232, CMOS/LSTTL ▶ Data Rates: 300 to 9,600 bps ▶ Parity Range: Even, Odd, Mark, Space, Ignore ▶ Control Bits: 1-Start and 1-Stop ▶ Standard Interface Connector: 6 Pin Female Modular Connector |

Environmental

- ▶ Nematic Display
 - Storage Temperature: -20°C to +70°C
 - Operating Standard Temperature: 0° to + 50°C, Extended Temperature: -20°C to +70°C
- ▶ Vacuum Fluorescent Display
 - Storage Temperature: -40° to + 85°C
 - Operating Temperature: -20° to + 70°C, Extended Temperature: -40° to + 70°C
- ▶ Humidity: 5-95% (Non-condensing)

Physical

- ▶ Height: 8.25.inches (209.6 mm)
- ▶ Width: 4.10 inches (104.1 mm)
- ▶ Depth: 1.15 inches (29.2 mm)
- ▶ Weight: 8 ounces (227 grams)
- ▶ Weight w/NiMH Battery: 18 ounces (510 grams)
- ▶ Case: General Electric Cyclocac ABS

Specifications are subject to change without notice

Figure A-1: TechTerm Case Dimensions

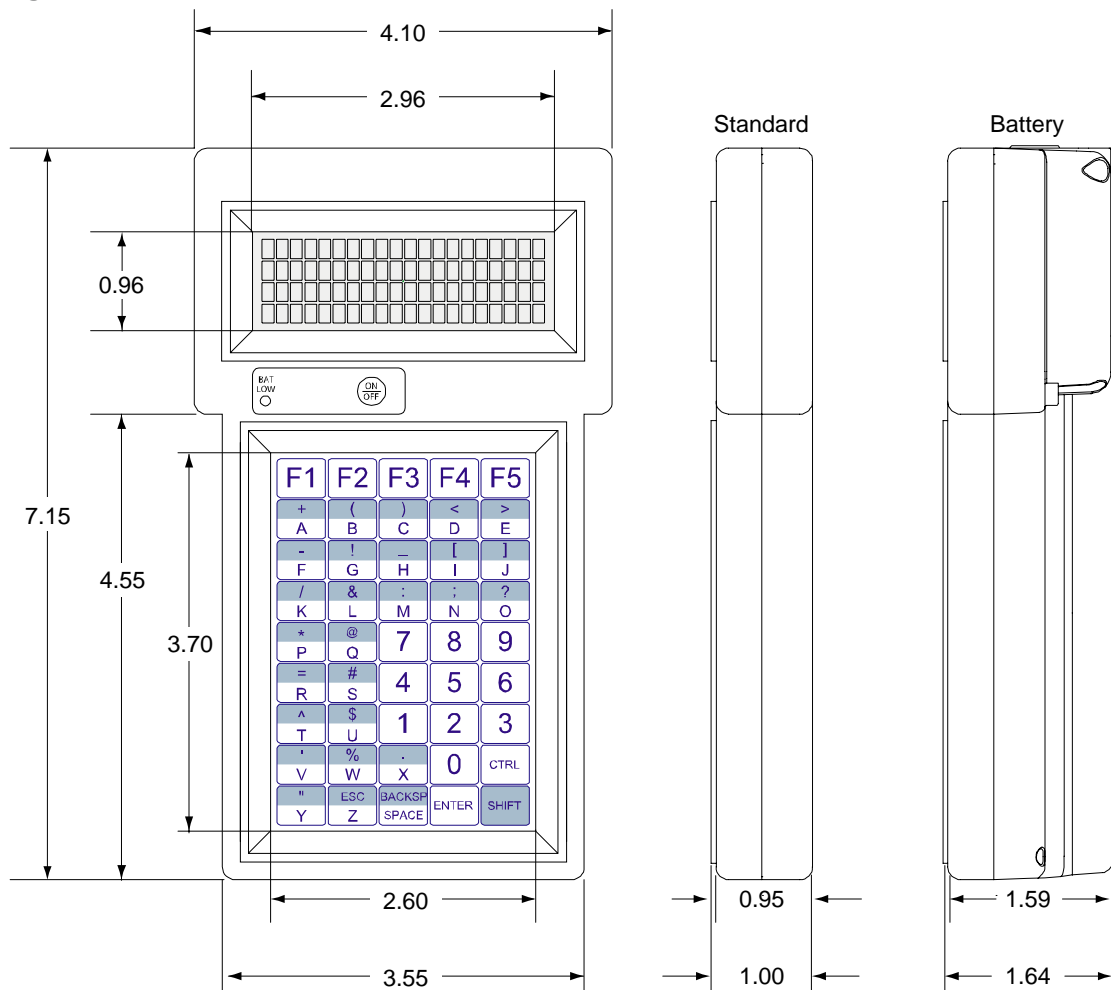



Appendix B: ASCII Character Set

Introduction

The following table contains the 80 Series ASCII character set and corresponding Decimal, Hex and Binary conversion codes as well as the keystroke entry for QWERTY style PC keyboards:

Table B-1: ASCII Character Set and Conversion Codes

| <i>ASCII</i> | <i>Decimal</i> | <i>HEX</i> | <i>Binary</i> | <i>PC Key</i> | <i>ASCII</i> | <i>Decimal</i> | <i>HEX</i> | <i>Binary</i> | <i>PC Key</i> |
|--------------|----------------|------------|---------------|---------------|--------------|----------------|------------|---------------|---------------|
| NUL | 0 | 00 | 00000000 | CTRL 1 | RS | 30 | 1E | 00011110 | CTRL = |
| SOH | 1 | 01 | 00000001 | CTRL A | US | 31 | 1F | 00011111 | CTRL - |
| STX | 2 | 02 | 00000010 | CTRL B | Space | 32 | 20 | 00100000 | Space |
| ETX | 3 | 03 | 00000011 | CTRL C | ! | 33 | 21 | 00100001 | ! |
| EOT | 4 | 04 | 00000100 | CTRL D | " | 34 | 22 | 00100010 | " |
| ENQ | 5 | 05 | 00000101 | CTRL E | # | 35 | 23 | 00100011 | # |
| ACK | 6 | 06 | 00000110 | CTRL F | \$ | 36 | 24 | 00100100 | \$ |
| BEL | 7 | 07 | 00000111 | CTRL G | % | 37 | 25 | 00100101 | % |
| BS | 8 | 08 | 00001000 | CTRL H | & | 38 | 26 | 00100110 | & |
| HT | 9 | 09 | 00001001 | CTRL I | ' | 39 | 27 | 00100111 | ' |
| LF | 10 | 0A | 00001010 | CTRL J | (| 40 | 28 | 00101000 | (|
| VT | 11 | 0B | 00001011 | CTRL K |) | 41 | 29 | 00101001 |) |
| FF | 12 | 0C | 00001100 | CTRL L | * | 42 | 2A | 00101010 | * |
| CR | 13 | 0D | 00001101 | CTRL M | + | 43 | 2B | 00101011 | + |
| SO | 14 | 0E | 00001110 | CTRL N | , | 44 | 2C | 00101100 | , |
| SI | 15 | 0F | 00001111 | CTRL O | - | 45 | 2D | 00101101 | - |
| DLE | 16 | 10 | 00010000 | CTRL P | . | 46 | 2E | 00101110 | . |
| DC1 | 17 | 11 | 00010001 | CTRL Q | / | 47 | 2F | 00101111 | / |
| DC2 | 18 | 12 | 00010010 | CTRL R | 0 | 48 | 30 | 00110000 | 0 |
| DC3 | 19 | 13 | 00010011 | CTRL S | 1 | 49 | 31 | 00110001 | 1 |
| DC4 | 20 | 14 | 00010100 | CTRL T | 2 | 50 | 32 | 00110010 | 2 |
| NAK | 21 | 15 | 00010101 | CTRL U | 3 | 51 | 33 | 00110011 | 3 |
| SYNC | 22 | 16 | 00010110 | CTRL V | 4 | 52 | 34 | 00110100 | 4 |
| ETB | 23 | 17 | 00010111 | CTRL W | 5 | 53 | 35 | 00110101 | 5 |
| CAN | 24 | 18 | 00011000 | CTRL X | 6 | 54 | 36 | 00110110 | 6 |
| EM | 25 | 19 | 00011001 | CTRL Y | 7 | 55 | 37 | 00110111 | 7 |
| SUB | 26 | 1A | 00011010 | CTRL Z | 8 | 56 | 38 | 00111000 | 8 |
| ESC | 27 | 1B | 00011011 | ESC | 9 | 57 | 39 | 00111001 | 9 |
| FS | 28 | 1C | 00011100 | CTRL< | : | 58 | 3A | 00111010 | : |
| GS | 29 | 1D | 00011101 | CTRL | ; | 59 | 3B | 00111011 | ; |

| <i>ASCII</i> | <i>Decimal</i> | <i>HEX</i> | <i>Binary</i> | <i>PC Key</i> | <i>ASCII</i> | <i>Decimal</i> | <i>HEX</i> | <i>Binary</i> | <i>PC Key</i> |
|--------------|----------------|------------|---------------|---------------|--------------|----------------|------------|---------------|---------------|
| < | 60 | 3C | 00111100 | < | W | 87 | 57 | 01010111 | W |
| = | 61 | 3D | 00111101 | = | X | 88 | 58 | 01011000 | X |
| @ | 64 | 40 | 01000000 | @ | Y | 89 | 59 | 01011001 | Y |
| A | 65 | 41 | 01000001 | A | Z | 90 | 5A | 01011010 | Z |
| B | 66 | 42 | 01000010 | B | [| 91 | 5B | 01011011 | [|
| C | 67 | 43 | 01000011 | C | \ | 92 | 5C | 01011100 | \ |
| D | 68 | 44 | 01000100 | D |] | 93 | 5D | 01011101 |] |
| E | 69 | 45 | 01000101 | E | ^ | 94 | 5E | 01011110 | ^ |
| F | 70 | 46 | 01000110 | F | _ | 95 | 5F | 01011111 | _ |
| G | 71 | 47 | 01000111 | G | ` | 96 | 60 | 01100000 | ` |
| H | 72 | 48 | 01001000 | H | a | 97 | 61 | 01100001 | a |
| I | 73 | 49 | 01001001 | I | b | 98 | 62 | 01100010 | b |
| J | 74 | 4A | 01001010 | J | c | 99 | 63 | 01100011 | c |
| K | 75 | 4B | 01001011 | K | d | 100 | 64 | 01100100 | d |
| L | 76 | 4C | 01001100 | L | e | 101 | 65 | 01100101 | e |
| M | 77 | 4D | 01001101 | M | f | 102 | 66 | 01100110 | f |
| N | 78 | 4E | 01001110 | N | g | 103 | 67 | 01100111 | g |
| O | 79 | 4F | 01001111 | O | h | 104 | 68 | 01101000 | h |
| P | 80 | 50 | 01010000 | P | i | 105 | 69 | 01101001 | i |
| A | 65 | 41 | 01000001 | A | j | 106 | 6A | 01101010 | j |
| B | 66 | 42 | 01000010 | B | k | 107 | 6B | 01101011 | k |
| C | 67 | 43 | 01000011 | C | l | 108 | 6C | 01101100 | l |
| D | 68 | 44 | 01000100 | D | m | 109 | 6D | 01101101 | m |
| E | 69 | 45 | 01000101 | E | n | 110 | 6E | 01101110 | n |
| F | 70 | 46 | 01000110 | F | o | 111 | 6F | 01101111 | o |
| G | 71 | 47 | 01000111 | G | p | 112 | 70 | 01110000 | p |
| H | 72 | 48 | 01001000 | H | q | 113 | 71 | 01110001 | q |
| I | 73 | 49 | 01001001 | I | r | 114 | 72 | 01110010 | r |
| J | 74 | 4A | 01001010 | J | s | 115 | 73 | 01110011 | s |
| K | 75 | 4B | 01001011 | K | t | 116 | 74 | 01110100 | t |
| L | 76 | 4C | 01001100 | L | u | 117 | 75 | 01110101 | u |
| M | 77 | 4D | 01001101 | M | v | 118 | 76 | 01110110 | v |
| N | 78 | 4E | 01001110 | N | w | 119 | 77 | 01110111 | w |
| O | 79 | 4F | 01001111 | O | x | 120 | 78 | 01111000 | x |
| P | 80 | 50 | 01010000 | P | y | 121 | 79 | 01111001 | y |
| Q | 81 | 51 | 01010001 | Q | z | 122 | 7A | 01111010 | z |
| R | 82 | 52 | 01010010 | R | { | 123 | 7B | 01111011 | { |
| S | 83 | 53 | 01010011 | S | | 124 | 7C | 01111100 | |
| T | 84 | 54 | 01010100 | T | } | 125 | 7D | 01111101 | } |
| U | 85 | 55 | 01010101 | U | → | 126 | 7E | 01111110 | |
| V | 86 | 56 | 01010110 | V | Delete | 127 | 7F | 01111111 | |



Appendix C: Keypad Hex Output Values

45-Key Keypad Hex Output

The following table contains the hex output for a standard 45-key keypad, where “CS” is CTRL + SHIFT (Locked) key output, “C” is CTRL key output, “S” is SHIFT key output and “U” is single key output.

Table C-1: 45-Key Keypad Hex Output Values

| Key = Hex | Key = Hex | Key = Hex | Key = Hex | Key = Hex |
|--|--|--|--|---|
| CS1 = 11 C1 ¹ = 1B 5B 41 S1 = 06 U1 = 11 | CS10 = 12 C10 ¹ = 1B 5B 42 S10 = 07 U10 = 12 | CS19 = 13 C19 ¹ = 1B 5B 43 S19 = 08 U19 = 13 | CS28 = 14 C28 ¹ = 1B 5B 44 S28 = 09 U28 = 14 | CS37 = 15 C37 ¹ = 1B 5B 45 S37 = 0A U3 = 15 |
| CS2 = 61 C2 = 01 S2 = 2B U2 = 41 | CS11 = 62 C11 = 02 S11 = 28 U11 = 42 | CS20 = 63 C20 = 03 S20 = 29 U20 = 43 | CS29 = 64 C29 = 04 S29 = 3C U29 = 44 | CS38 = 65 C38 = 05 06 S38 = 3E U38 = 45 |
| CS3 = 66 C3 = 06 S3 = 2D U3 = 46 | CS12 = 67 C12 = 07 S12 = 21 U12 = 47 | CS1 = 68 C21 = 08 S21 = 5F U21 = 48 | CS1 = 69 C30 = 09 S30 = 5B U30 = 49 | CS1 = 6A C39 = 0A S39 = 5D U39 = 4A |
| CS4 = 6B C4 = 0B S4 = 2F U4 = 4B | CS13 = 6C C13 = 0C S13 = 26 U13 = 4C | CS22 = 6D C22 = 0D S22 = 3A U22 = 4D | CS31 = 6E C31 = 0E S31 = 3B U31 = 4E | CS40 = 6F C40 = 0F S40 = 3F U40 = 4F |
| CS5 = 70 C5 = 10 S5 = 2A U5 = 50 | CS14 = 71 C14 = 11 S14 = 40 U14 = 51 | CS23 = 37 C23 = __ S23 = 37 U23 = 37 | CS32 = 38 C32 = __ S32 = 38 U32 = 38 | CS41 = 39 C41 = __ S41 = 39 U41 = 39 |
| CS6 = 72 C6 = 12 S6 = 3D U6 = 52 | CS15 = 73 C15 = 13 S15 = 23 U15 = 53 | CS24 = 34 C24 = __ S24 = 34 U24 = 34 | CS33 = 35 C33 = __ S33 = 35 U33 = 35 | CS42 = 36 C42 = __ S42 = 36 U42 = 36 |
| CS7 = 74 C7 = 14 S7 = 5E U7 = 54 | CS16 = 75 C16 = 15 S16 = 24 U16 = 55 | CS25 = 31 C25 = __ S25 = 31 U25 = 31 | CS32 = 32 C34 = __ S34 = 32 U34 = 32 | CS43 = 33 C43 = __ S43 = 33 U43 = 33 |
| CS8 = 76 C8 = 16 S8 = 2C U8 = 56 | CS17 = 77 C17 = 17 S17 = 25 U17 = 57 | CS26 = 78 C26 = 18 S26 = 2E U26 = 58 | CS35 = 30 C35 = __ S35 = 30 U35 = 30 | CTRL |
| CS9 = 79 C9 = 19 S9 = 22 U9 = 59 | CS18 = 7A C18 = 1A S18 = 1B U18 = 5A | CS27 = 20 C27 = 20 S27 = 08 U27 = 20 | CS36 = 0D C36 = 0D S36 = 0D U36 = 0D | SHIFT |

1. While in Private mode, C1, C10, 19, C28 and C37 will not return a 5Bh (e.g., C1 = 1B 41, C2 = 1B 42, etc).

30-Key Keypad Hex Output

The following table contains the hex output for a standard 30-key keypad, where “CS” is CTRL + SHIFT (Locked) key output, “C” is CTRL key output, “S” is SHIFT key output and “U” is single key output.

Table C-2: 30-Key Keypad Hex Output Values

| Key = Hex | Key = Hex | Key = Hex | Key = Hex | Key = Hex |
|--|---|---|---|--|
| CS1 = 61 C1 = 01 S1 = 11 U1 = 41 | CS7 = 62 C7 = 02 S7 = 12 U7 = 42 | CS13 = 63 C13 = 03 S13 = 13 U13 = 43 | CS19 = 64 C19 = 04 S19 = 14 U19 = 44 | CS25 = 65 C25 = 05 06 S25 = 15 U25 = 45 |
| CS2 = 66 C2 = 06 S2 = 2F U2 = 46 | CS8 = 67 C8 = 07 S8 = 28 U8 = 47 | CS14 = 68 C14 = 08 S14 = 31 U14 = 48 | CS20 = 69 C20 = 09 S20 = 32 U20 = 49 | CS26 = 6A C26 = 0A S26 = 33 U26 = 4A |
| CS3 = 6B C3 = 0B S3 = 2A U3 = 4B | C9 = 6C C9 = 0C S9 = 29 U9 = 4C | CS15 = 6D C15 = 0D S15 = 34 U15 = 4D | CS21 = 6E C21 = 0E S21 = 35 U21 = 4E | CS27 = 6F C27 = 0F S27 = 36 U27 = 4F |
| CS4 = 70 CS4 = 10 S4 = 2D U4 = 50 | CS10 = 71 C10 = 11 S10 = 23 U10 = 51 | CS16 = 72 C16 = 12 S16 = 37 U16 = 52 | CS22 = 73 C22 = 13 S22 = 38 U22 = 53 | CS28 = 74 C28 = 14 S28 = 39 U28 = 54 |
| CS5 = 75 CS5 = 15 S5 = 2B U5 = 55 | CS11 = 76 C11 = 16 S11 = 2C U11 = 56 | CS17 = 77 C17 = 17 S17 = 3D U17 = 57 | CS23 = 78 C23 = 18 S23 = 30 U23 = 58 | CS29 = 79 C29 = 19 S29 = 2E U29 = 59 |
| CS6 = 7A C6 = 1A S6 = 1B U6 = 5A | CS12 = 20 C12 = — S12 = 08 U12 = 20 | CS18 = 0D C18 = — S18 = 0D U18 = 0D | CTRL | SHIFT |

20-Key Keypad Hex Output

The following table contains the hex output for a standard 20-key keypad:

Table C-3: 20-Key Keypad Hex Output Values

| Key = Hex | Key = Hex | Key = Hex | Key = Hex |
|-----------|-----------|-----------|-----------|
| 1 = 41 | 6 = 42 | 11 = 43 | 16 = 44 |
| 2 = 31 | 7 = 32 | 12 = 33 | 17 = 2B |
| 3 = 34 | 8 = 35 | 13 = 36 | 18 = 2D |
| 4 = 37 | 9 = 38 | 14 = 39 | 19 = — |
| 5 = 2E | 10 = 30 | 15 = 20 | 20 = — |



Index

A

| | |
|------------------------------|-----|
| About the TechTerm..... | 1-2 |
| About this Manual..... | 1-1 |
| About Two Technologies..... | 1-1 |
| Alert..... | 5-2 |
| ANSI Mode Host Commands..... | 5-1 |
| ASCII Character Set..... | B-1 |

B

| | |
|--------------------------|-----|
| Battery Orientation..... | 2-5 |
| Baud Rate..... | 3-1 |

C

| | |
|----------------------------------|----------|
| Cable and Power Connections..... | 2-2 |
| Cable Connections..... | 2-4 |
| Case Dimensions..... | A-2 |
| Changing Batteries..... | 2-5 |
| Changing Parameter Settings..... | 3-3 |
| Charging the Unit..... | 2-5 |
| Connecting the Terminal..... | 2-3 |
| Control Code Commands..... | 5-4 |
| Controls and Indicators..... | 2-1 |
| CPU Specifications..... | A-1 |
| Current Draw..... | vii |
| Cursor Down..... | 5-1 |
| Cursor Home..... | 5-2 |
| Cursor Home & Clear Display..... | 5-2 |
| Cursor Left..... | 5-1 |
| Cursor Position..... | 2-6, 5-3 |
| Cursor Right..... | 5-1 |
| Cursor Up..... | 5-1 |

D

| | |
|------------------------------|----------|
| Data Bits..... | 3-1 |
| Defining Key Output..... | 4-2 |
| Disable Blinking Cursor..... | 5-2 |
| Disable Cursor..... | 5-2 |
| Disable Key Click..... | 5-3 |
| Display..... | 1-2, 2-1 |
| Display Operation..... | 2-6 |
| Display PE..... | 3-1 |
| Display Specifications..... | A-1 |

| | |
|-----------------|-----|
| Durability..... | 1-2 |
|-----------------|-----|

E

| | |
|-------------------------------------|-----|
| Echo..... | 3-2 |
| Enable Blinking Cursor..... | 5-2 |
| Enable Cursor..... | 5-2 |
| Enable Key Click..... | 5-3 |
| Environmental Specifications..... | A-2 |
| Erase Cursor to End of Display..... | 5-2 |
| Erase Cursor to End of Line..... | 5-2 |
| Erase Entire Line..... | 5-2 |
| Escape Command Summary..... | 5-4 |

F

| | |
|--------------------------|-----|
| Function Key Values..... | 4-1 |
|--------------------------|-----|

H

| | |
|-------------------|-----|
| Handshake..... | 3-2 |
| Host Control..... | 2-7 |

I

| | |
|-------------------------------------|-----|
| Index..... | I-1 |
| Interface Options..... | 1-2 |
| Interface Specifications..... | A-1 |
| Internal Communication Devices..... | 2-2 |

K

| | |
|----------------------------------|----------|
| Key & Switch Specifications..... | A-1 |
| Key Click..... | 5-2 |
| Key Programming..... | 4-1 |
| Keypad..... | 1-2, 2-1 |
| Keypad Hex Output Values..... | C-1 |
| 20-Key Keypad..... | C-2 |
| 30-Key Keypad..... | C-2 |
| 45-Key Keypad..... | C-1 |
| Keypad Operation..... | 2-6 |

L

| | |
|---------------------------------------|-----|
| Loading Factory Default Settings..... | 3-3 |
| Long Bell..... | 5-2 |
| Low Battery Indicator..... | 2-1 |
| LT1281..... | 2-2 |

LTC4902-2

M

Manual Configuration.....3-1

Modular Interface Connector 2-1, 2-2

Modular Interface Connector Signal and Pin
Assignments.....2-2

O

Operating Modes2-7

Operation2-1

Overview1-1

P

Parameter Menu Settings.....3-1

Parameter Menu Summary3-2

Parity3-1

Parity Error3-1

PCLAT Wired Adapter2-3

Physical SpecificationsA-2

Power..... 1-2, 2-4

 Battery-Powered Units 2-4

 Line-Powered Units 2-4

Power Requirements vii

Power Saver3-2

Power Specifications A-1

Power Switch2-1

Product Selection Guide vi

R

Repeat 3-2

Restricting Access..... 3-4

Return Terminal Identifier String..... 5-3

RS-2322-2

RS-4222-2

S

Save Cursor Position..... 5-2

Self-Test3-2

Short Bell 5-2

Signal and Pin Interface Assignments 2-2

Specifications A-1

Standard Accessory Cables..... 2-3

Switches and Indicators..... 1-2

Symbols and Conventions..... 1-1

T

TechTerm Features 1-2

Troubleshooting 6-1